

MOUNTING INSTRUCTIONS

Stacking kit for washing machines and tumble dryers

INSTRUCTIONS DE MONTAGE

**Kit pour le montage en colonne de machines à laver
et de sèche-linge**

MONTAGEANLEITUNG

Bausatz für die Montage als Wasch-Trockner-Säule

INSTRUCTIES VOOR MONTAGE

**Kit voor het boven elkaar monteren van
wasmachines en wasdrogers**

ISTRUZIONI PER IL MONTAGGIO

Kit per il montaggio in colonna di lavatrice e asciugatrice

INSTRUCCIONES DE INSTALACIÓN

**Kit para la instalación en columna de lavadoras
y secadoras**

INSTRUÇÕES DE MONTAGEM

**Kit para a montagem em coluna de máquinas
de lavar e secar roupa**

MONTERINGSANVISNINGER

Udstyr til montering i vaskesøjle

MONTERINGSINSTRUKSJONER

Sett til vaskesøyle

MONTERINGSANVISNING

Monteringssats för tvättpelare

ASENNUSOHJEET

Pesukoneen ja kuivausrummun torniin asennussarja

ИНСТРУКЦИЯ ПО МОНТАЖУ

**Набор для установки друг на друга стиральных
и сушильных машин**

ΟΔΗΓΙΕΣ ΣΥΝΑΡΜΟΛΟΓΗΣΗΣ

**Kit για τη συναρμολόγηση σε στήλη πλυντηρίων
και στεγνωτηρίων**

MONTAJ BİLGİLERİ

Çamaşır makineleri ve kurutucuların kolon montajı takımı

Stacking kit for washing machines and tumble dryers

The creation of the stacking kit and in order to save space is available for all the front-loading washing machines which are 60 cm wide and have a depth which goes from 55 to 60 cm.

Procedure:

- Turn the tumble dryer on the right side making sure not to damage the cabinet
- Remove the front feet (fig. 1) and substitute them with the relative rubber feet (fig. 1a).

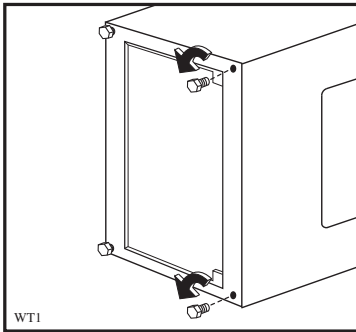

Fig 1

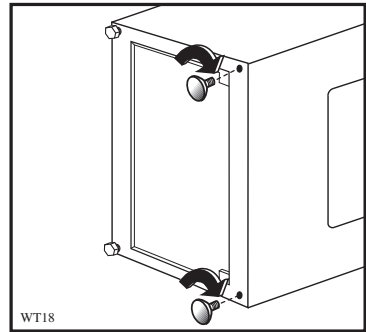

Fig 1a

- Place the tumble dryer on the top of the washing machine and unscrew the 2 screws, on the right and left side on the back of the tumble dryer.
- Place the relative metal fixing plates (fig. 2b/3b) and fix them with the included screws (A+B) both on the tumble dryer and on the upper corners.

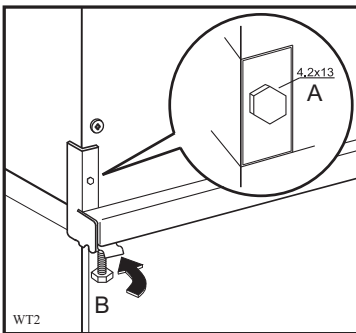

Fig 2 Small metal fixing plate

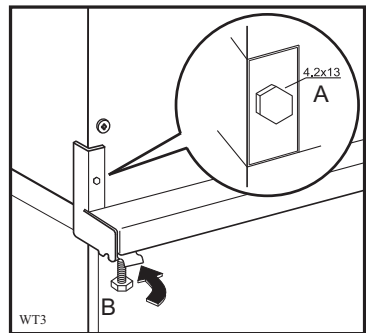

Fig 3 Large metal fixing plate

Screws A = self-tapping screws 4,2 x 13

Screws B = screw positioning

The figures below illustrate which metal plate according to the feet has to be used for the various washing machine and tumble dryer models.

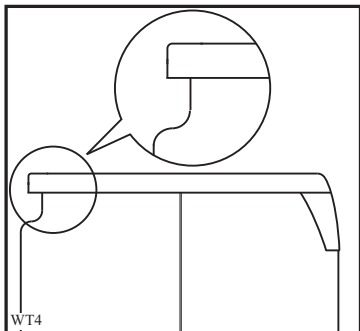

Fig 2a
Washing machines with top corner which protrudes a little.

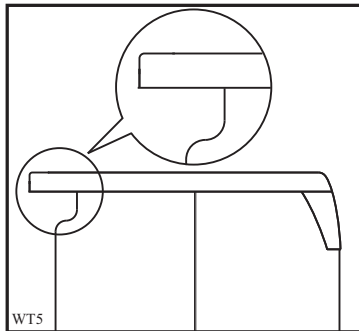

Fig 3a
Washing machines with top corner which protrudes a lot.

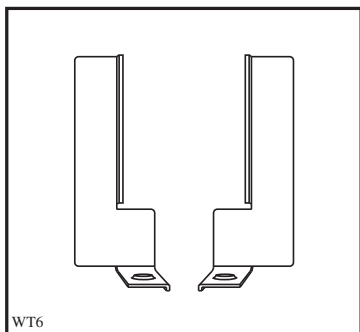

Fig 2b
Small metal fixing plate to be used on top corner washing machine which protrudes a little.

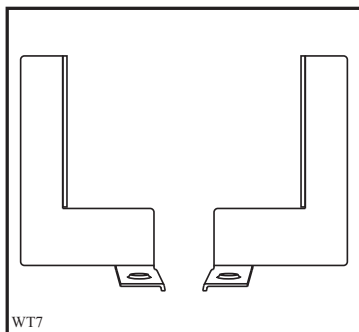

Fig 3b
Large metal fixing plate to be used on top corner washing machine which protrudes a lot.

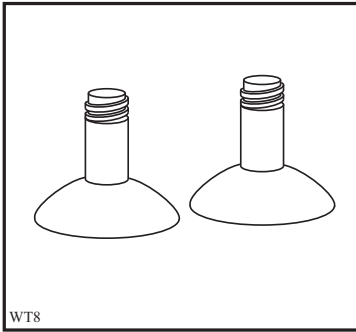

Fig 4

Long rubber feet (fig 4) to be used for the following tumble dryer models:

- Models without plinth (fig 5 and 6);
- Models with small door in plinth of the appliance (fig 7 and 8).

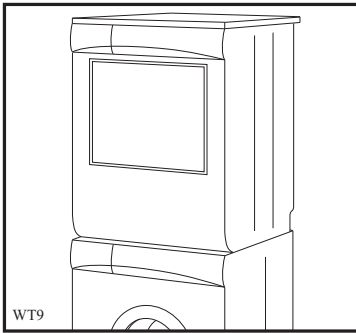

Fig 5

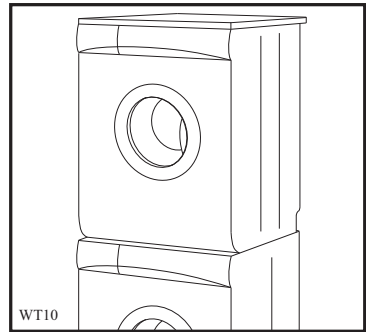

Fig 6

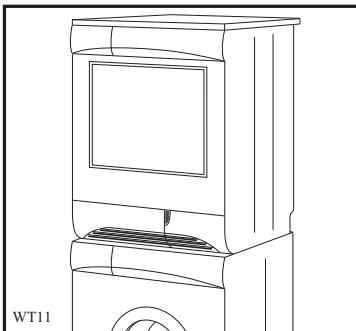

Fig 7

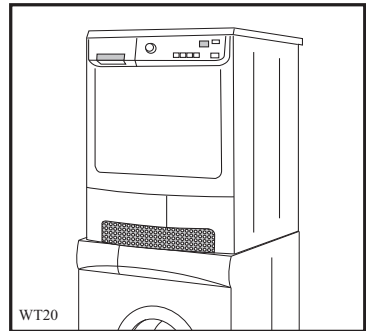
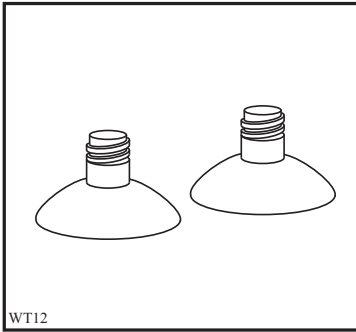

Fig 8



WT12

Fig 9

Short rubber feet (fig 9) to be used for the following tumble dryers models:

- Models with plinth (fig 10, 11, 12 and 13).

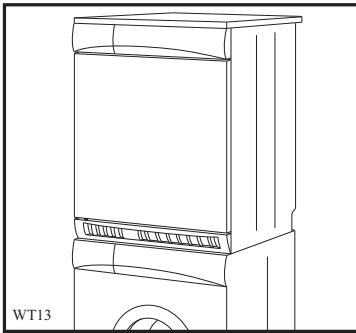

WT13

Fig 10

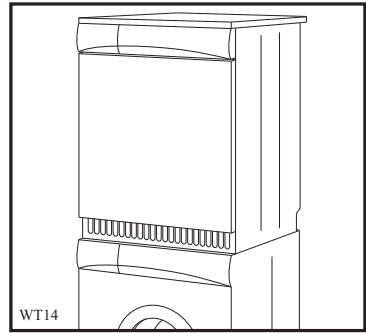

WT14

Fig 11

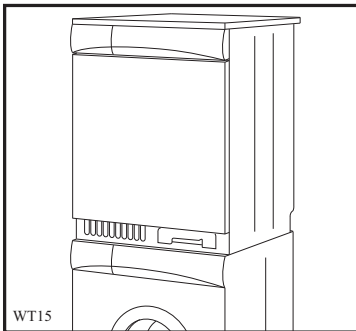

WT15

Fig 12

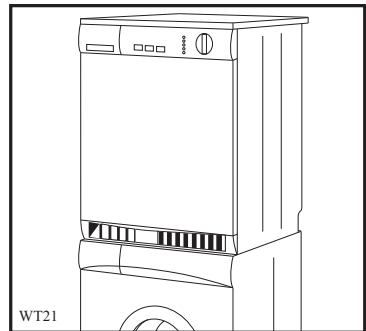

WT21

Fig 13

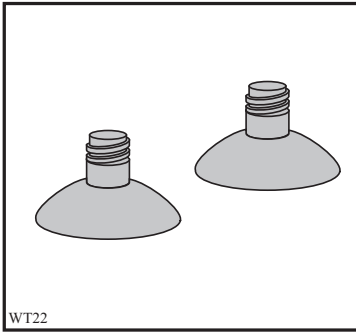

Fig 14

Grey short rubber feet (fig 14) to be used for the following tumble dryers models:

- Models with small door in plinth of the appliance (fig 15, 16 and 17).

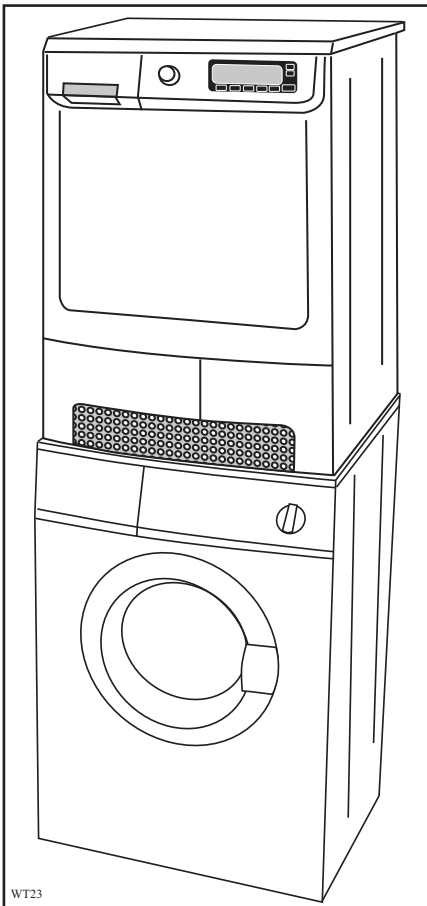

Fig 15

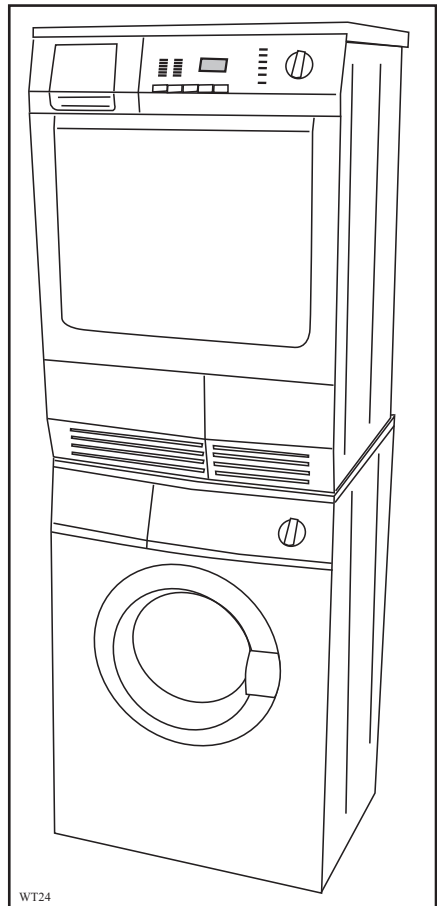
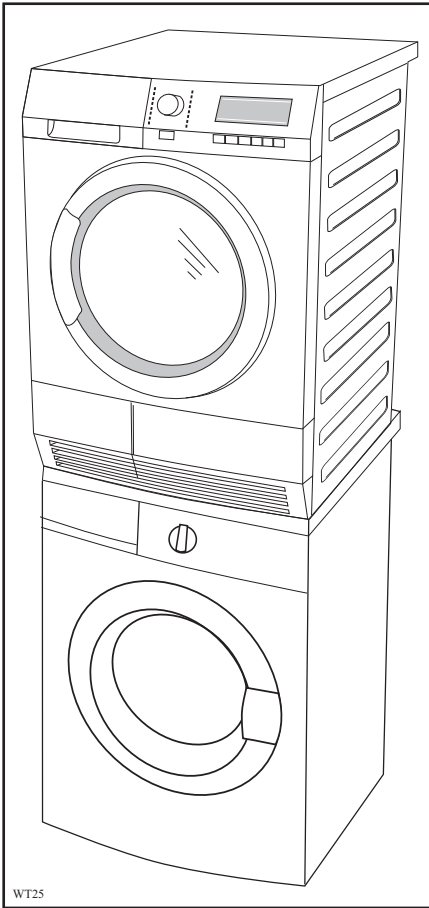

Fig 16



WT25

Fig 17

Kit pour le montage en colonne de machines à laver et de sèche-linge

Le kit de montage en colonne, conçu pour réduire l'espace occupé, est disponible pour toutes les machines à laver à chargement frontal, ayant une largeur de 60 cm et une profondeur comprise entre 55 et 60 cm.

Procédure:

- Appuyer le sèche-linge sur le côté droit en faisant très attention à ne pas endommager la structure.
- Enlever les petits pieds de devant (fig. 1) et les remplacer par des petits pieds correspondants en caoutchouc (fig. 1a).

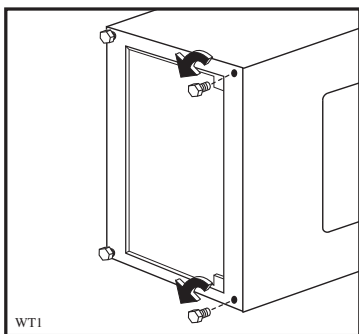

Fig 1

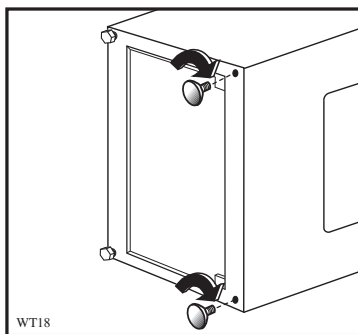

Fig 1a

- Positionner le sèche-linge au-dessus de la machine à laver et dévisser les 2 vis qui se trouvent sur les côtés droit et gauche du sèche-linge.
- Monter les plaquettes métalliques de fixation correspondantes (fig. 2b/3b), et les fixer à l'aide des vis fournies (A+B) aussi bien sur le sèche-linge que sur bords supérieurs.

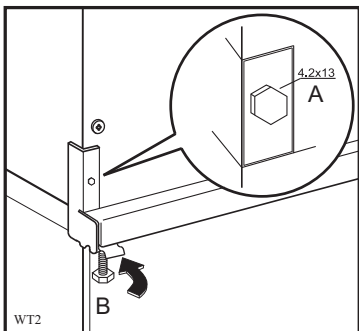

Fig 2 Plaquette métallique de fixation petit modèle

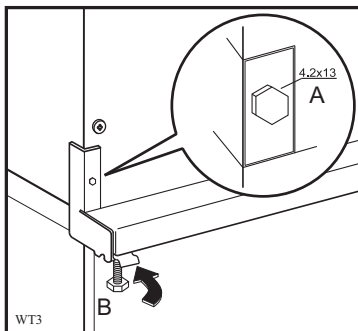

Fig 3 Plaquette métallique de fixation grand modèle

Vis A = vis autotaraudeuses 4,2x13

Vis B = positionnement des vis

Les figures qui suivent illustrent le type de plaquettes métalliques à utiliser selon les pieds, pour les différents modèles de machines à laver et de sèche-linge.

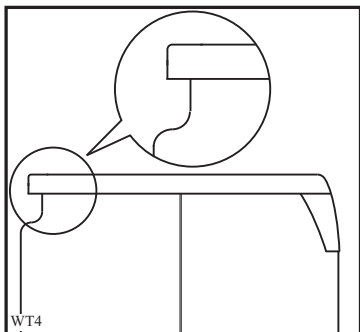

Fig 2a

Machine à laver avec bord supérieur qui dépasse peu.

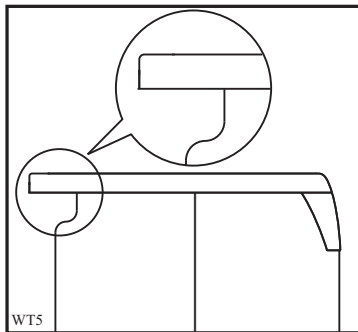

Fig 3a

Machine à laver avec bord supérieur qui dépasse beaucoup.

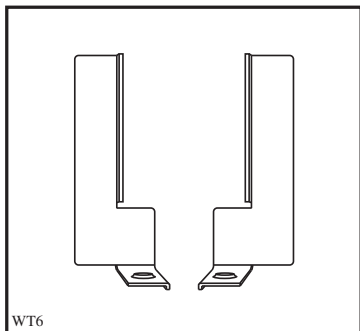

Fig 2b

Plaquette métallique de fixation petit modèle, à utiliser pour les machines à laver qui possèdent un bord supérieur qui dépasse peu.

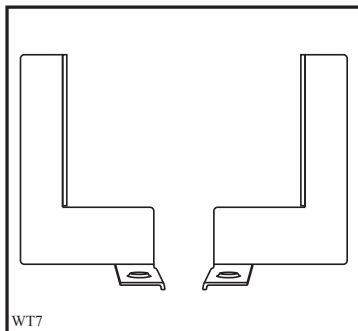

Fig 3b

Plaquette métallique de fixation grand modèle, à utiliser pour les machines à laver qui possèdent un bord supérieur qui dépasse beaucoup.

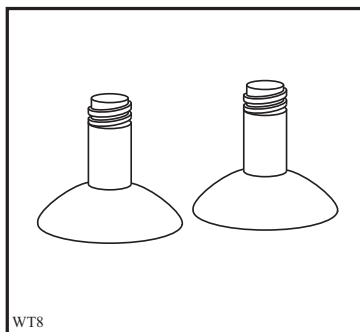

Fig 4

Pieds longs en caoutchouc (fig. 4), à utiliser pour les modèles de sèche-linge suivants:

- modèles sans élément socle (fig. 5 et 6);
- modèles avec petite porte sur l'élément socle (fig. 7 et 8).

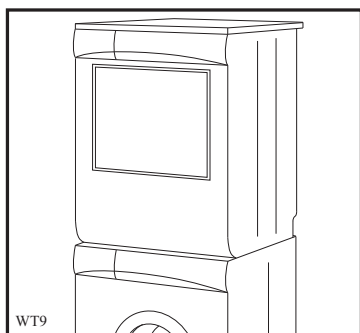

Fig 5

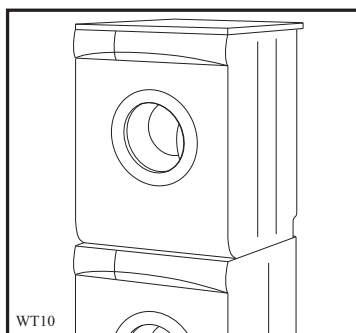

Fig 6

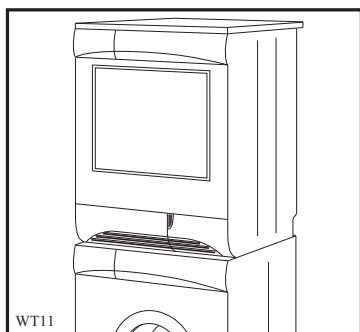

Fig 7

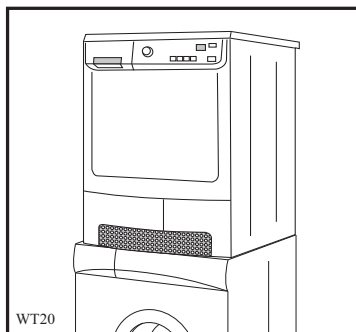

Fig 8

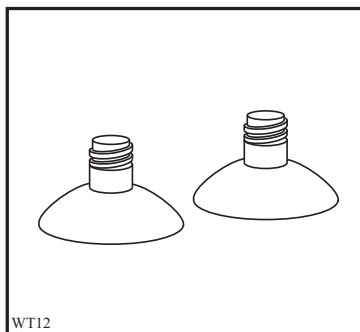

Fig 9

Pieds courts en caoutchouc (fig. 9), à utiliser pour les modèles de sèche-linge suivants:

- modèles avec élément socle (fig. 10, 11, 12 et 13).

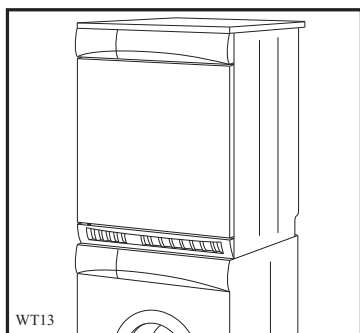

Fig 10

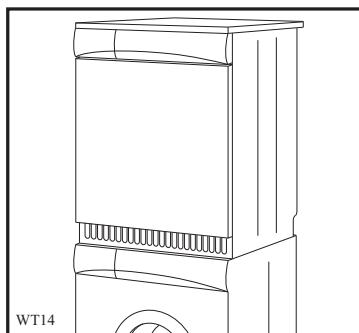

Fig 11

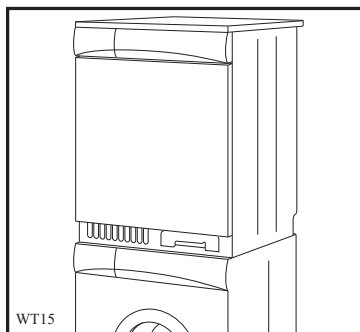

Fig 12

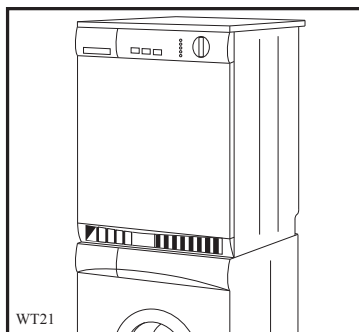

Fig 13

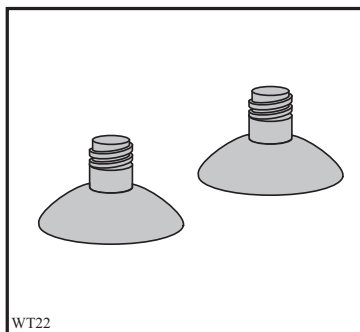

Fig 14

Pieds courts gris en caoutchouc (fig. 14), à utiliser pour les modèles de sèche-linge suivants:

- modèles avec petite porte sur l'élément socle. (fig 15, 16 et 17).

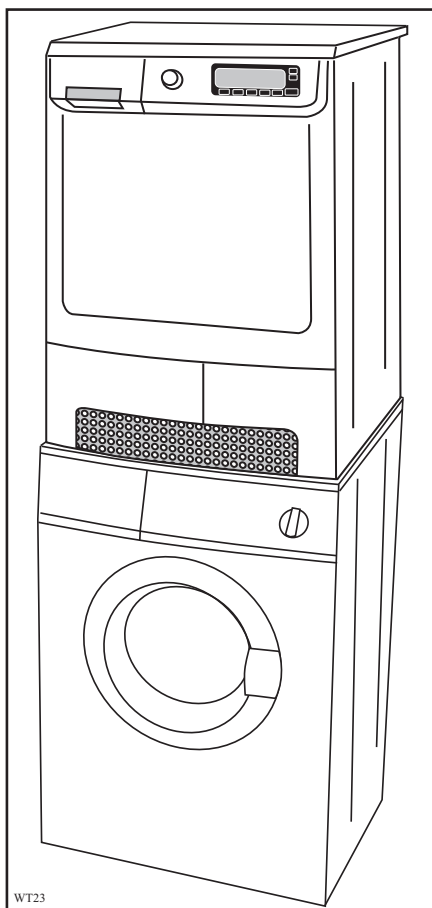

Fig 15

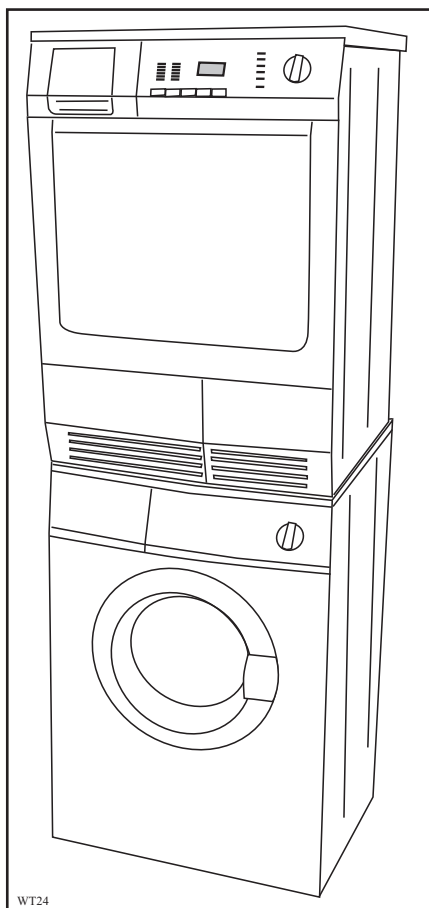
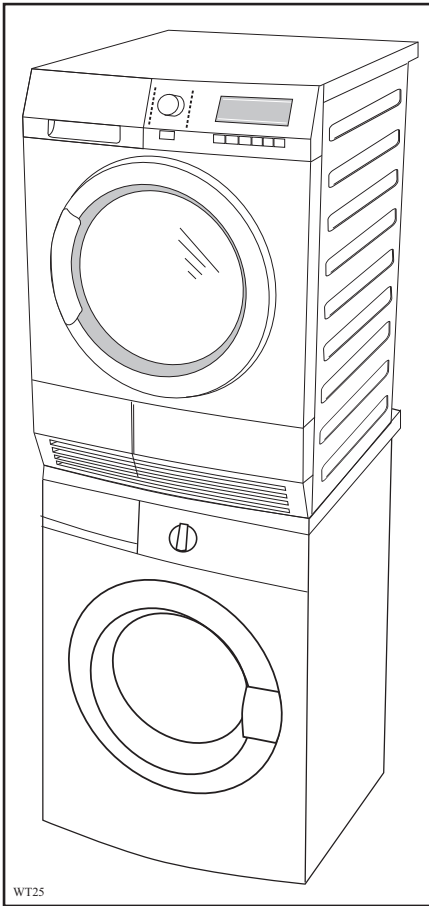

Fig 16



WT25

Fig 17

Bausatz für die Montage als Wasch-Trockner-Säule

Der Bausatz für die Wasch-Trockner-Säule dient für einen platz sparenden Einbau und ist für alle Frontlader-Waschautomaten mit 60 cm Breite und zwischen 55 und 60 cm Tiefe verfügbar.

Vorgehensweise:

- Den Trockner auf die rechte Seitenwand legen und darauf achten, dass die Struktur nicht beschädigt wird.
- Die vorderen Stellfüße (Abb. 1) abnehmen und durch die GummifüÙe (Abb. 1a) ersetzen.



Abb. 1



Abb. 1a

- Den Trockner auf den Waschautomaten stellen und die 2 Schrauben rechts und links an der Trocknerrückseite ausschrauben.
- Die dementsprechenden Befestigungsbleche (Abb. 2b/3b) montieren und mit den mitgelieferten Schrauben (A+B) sowohl am Trockner, als auch an den oberen Kanten fixieren.

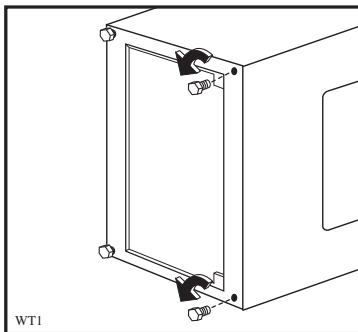

Abb. 2 Kleines Befestigungsblech

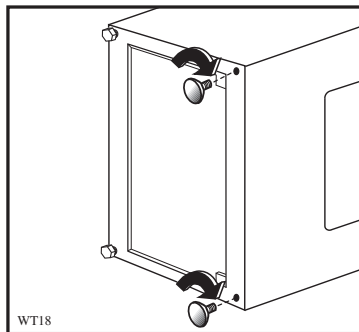

Abb. 3 Großes Befestigungsblech

Schrauben A = selbstschneidende Schrauben 4,2x13

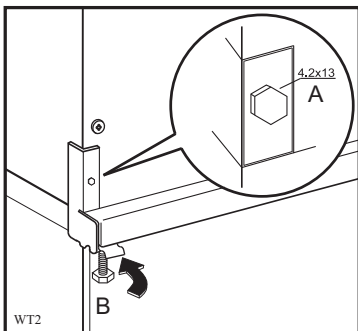
Schrauben B = Anordnung Schrauben

Die anstehenden Abbildungen zeigen die Art des zu verwendenden Befestigungsblechs je nach Stellfüßen für die diversen Waschautomat- und Trocknermodelle.

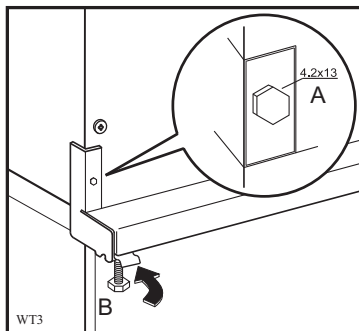

Abb. 2a

Waschautomaten mit wenig vorstehender Oberkante..

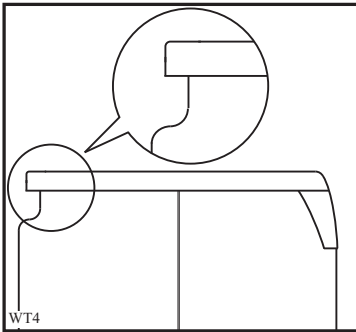

Abb.3a

Waschautomaten mit stark vorstehender Oberkante..

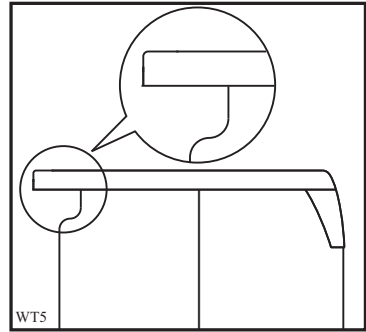

Abb. 2b

Kleines Befestigungsblech zur Verwendung für Waschautomaten mit wenig vorstehender Oberkante.

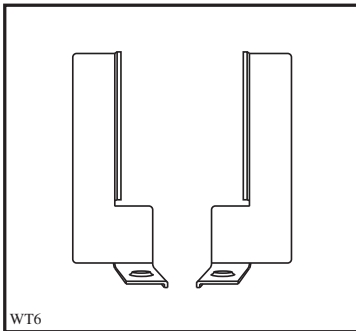

Abb. 3b

Großes Befestigungsblech zur Verwendung für Waschautomaten mit stark vorstehender Oberkante.

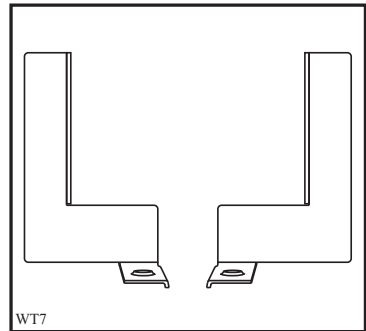

Abb. 4

Lange GummifüÙe (Abb. 4) für folgende Trocknermodelle:

- Modelle ohne Sockel (Abb. 5 und 6);
- Modelle mit Klappe am Sockel (Abb. 7 und 8).

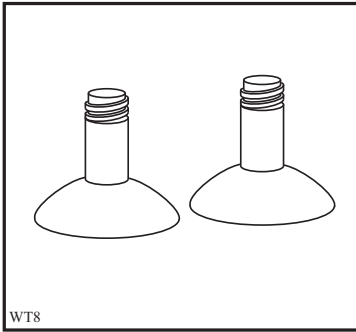

Abb. 5



Abb. 6

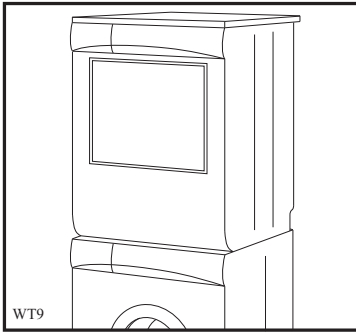

Abb. 7

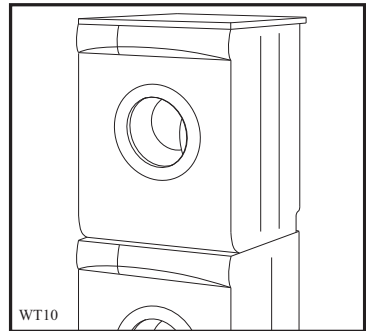

Abb. 8

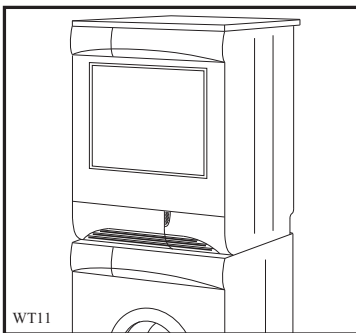

Abb. 9

Kurze GummifüÙe (Abb. 9) für folgende Trocknermodelle:

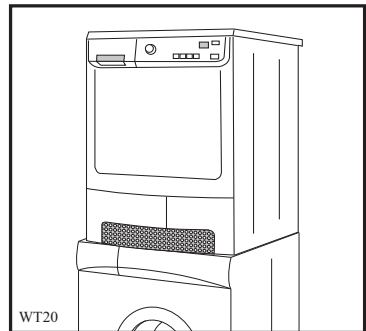
- Modelle mit Sockel (Abb. 10, 11, 12 und 13).

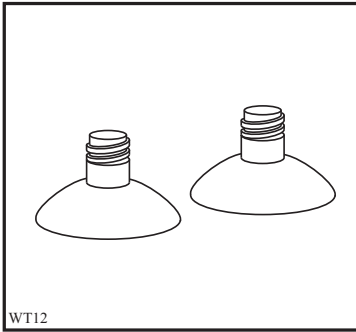

Abb. 10



Abb. 11

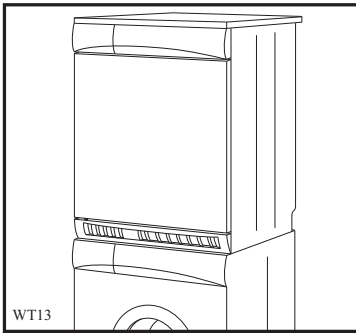

Abb. 12

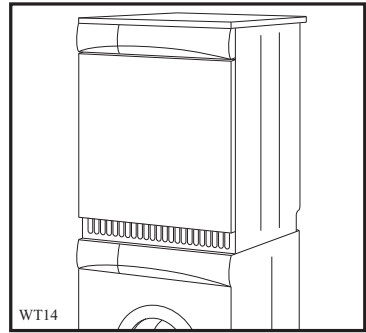

Abb. 13

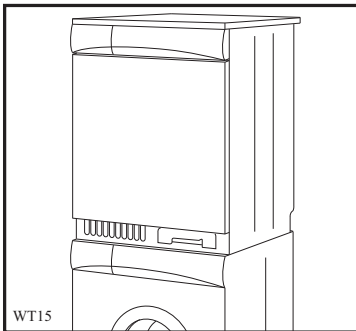

Abb. 14

Kurze grau GummifüÙe (Abb. 14) für folgende Trocknermodelle:

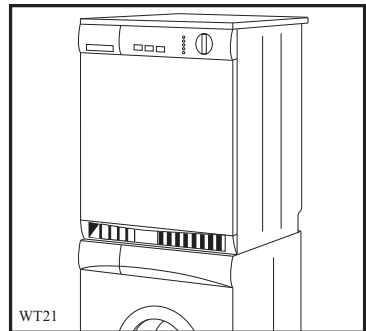
- Modelle mit Klappe am Sockel (Abb. 15, 16 und 17).

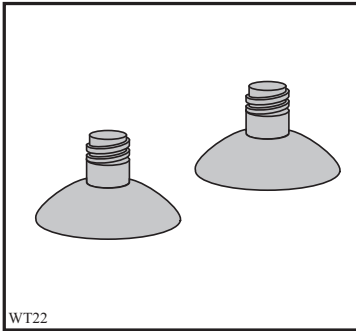

Abb. 15



Abb. 16

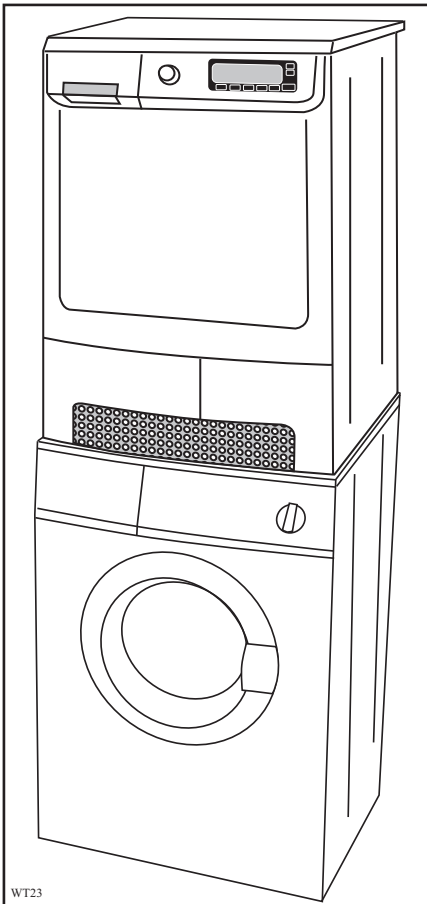

WT25

Fig 17

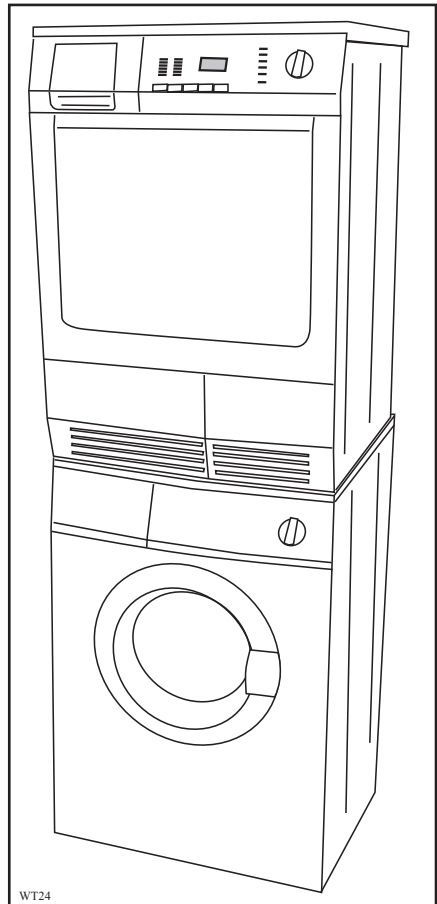
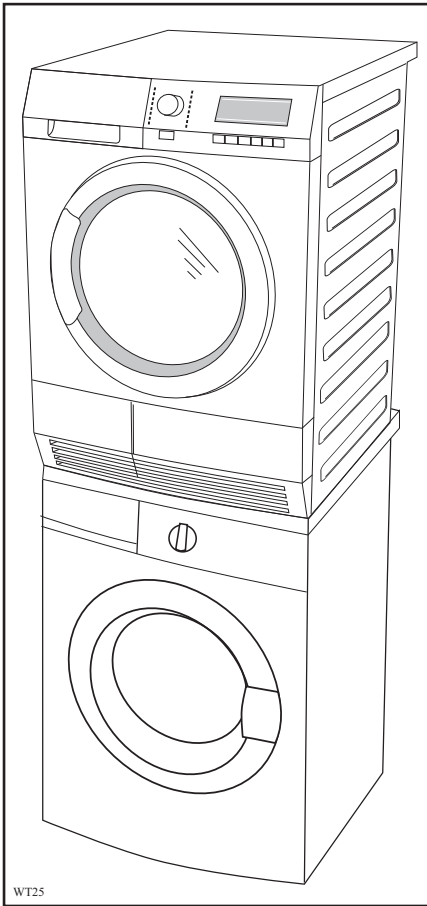
Kit voor het boven elkaar monteren van wasmachines en wasdrogers

Kit voor het boven elkaar monteren om de gebruikte ruimte te verkleinen is te gebruiken voor alle wasmachines met een laadopening aan de voorzijde met een grootte van 60 cm en een diepte tussen 55 en 60 cm.

Procedure:

- Plaats de droger op zijn rechterzijde terwijl u er op let dat u de wasdroger niet beschadigt
- Verwijder de voetjes aan de voorzijde (fig. 1) en monteer daarvoor in de plaats de daarmee corresponderende rubberen voetjes (fig. 1a).

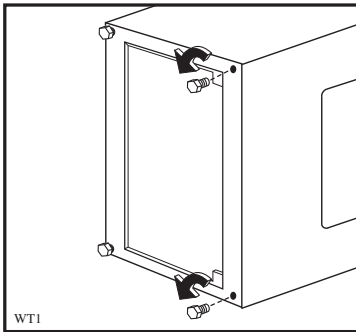

Fig 1

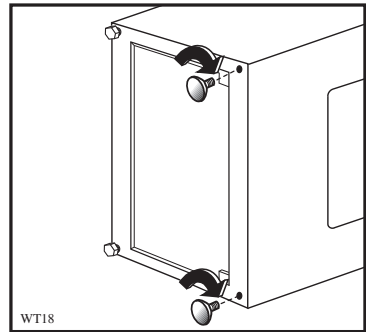

Fig 1a

- Plaats de wasdroger op de wasmachine en schroef 2 schroeven los die zich bevinden aan de rechter- en linkerzijde van de achterkant van de wasdroger.
- Monteer de corresponderende metalen bevestigingsplaatjes (fig. 2b/3b) en bevestig deze met de bijgeleverde schroeven (A+B) zowel op de wasdroger als op de bovenrand.

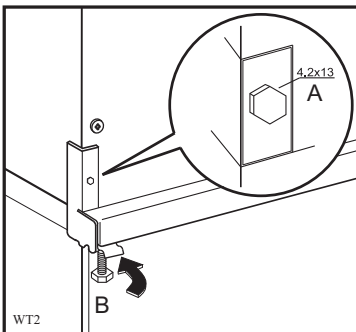

Fig 2 Klein metalen bevestigingsplaatje

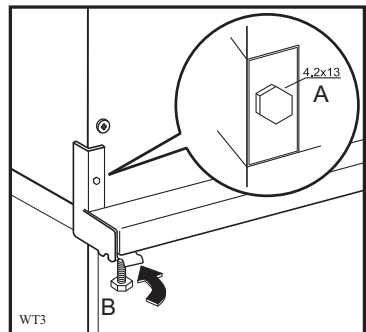

Fig 3 Groot metalen bevestigingsplaatje

Schroeven A = zelftappende schroeven 4,2x13

Schroeven B = plaatsingsschroeven

De volgende figuren illustreren het type metalen plaatje dat gebruikt dient te worden al naargelang van de voetjes voor de verschillende modellen was- en droogmachines.

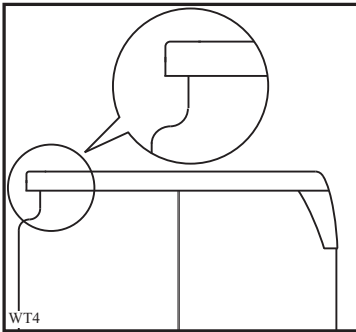

Fig 2a

Wasmachines met een bovenrand die weinig uitsteekt.

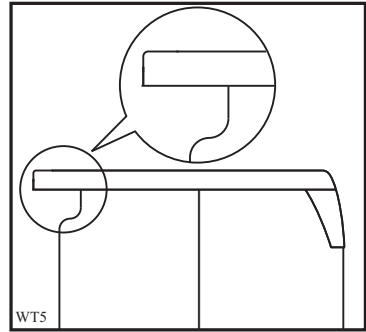

Fig 3a

Wasmachines met een bovenrand die ver uitsteekt.

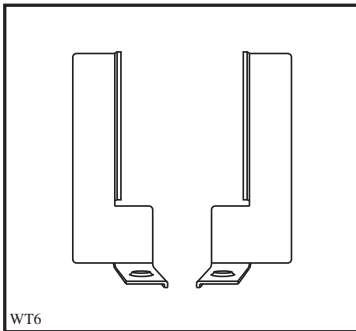

Fig 2b

Klein metalen bevestigingsplaatje te gebruiken voor wasmachines met een bovenrand die weinig uitsteekt.

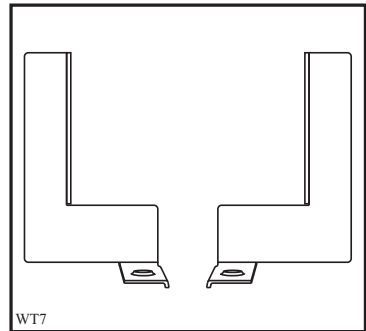

Fig 3b

Groot metalen bevestigingsplaatje te gebruiken voor wasmachines met een bovenrand die ver uitsteekt.

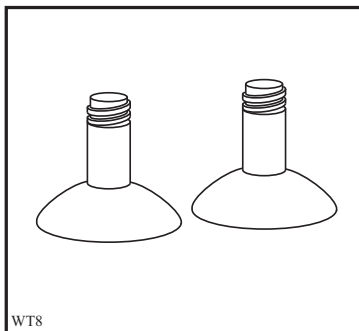

Fig 4

Lange rubberen voetjes (fig. 4) te gebruiken voor de volgende modellen wasdrogers:

- modellen zonder voetstuk (fig. 5 en 6);
- modellen met een luikje in het voetstuk (fig. 7 en 8).

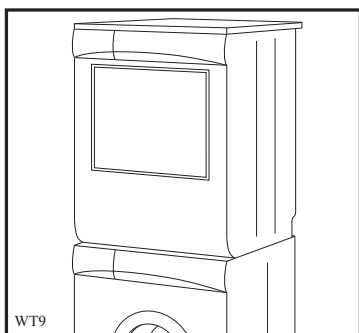

Fig 5

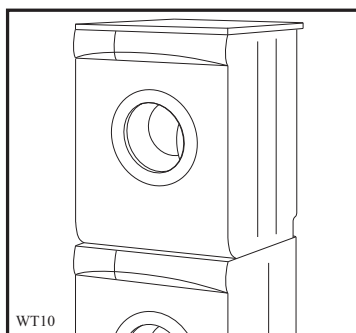

Fig 6

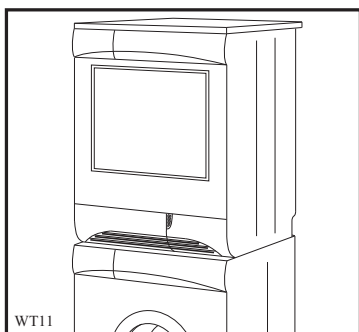

Fig 7

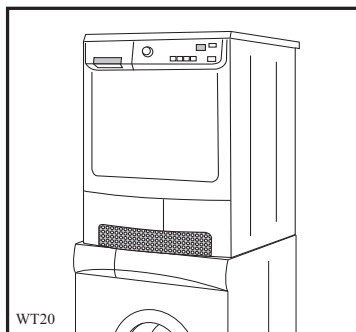

Fig 8

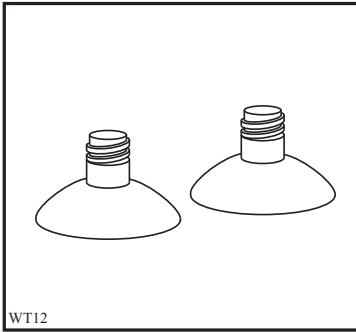

Fig 9

Korte rubberen voetjes (fig. 9) te gebruiken voor de volgende modellen wasdrogers:

- modellen met voetstuk (fig. 10, 11, 12 en 13).

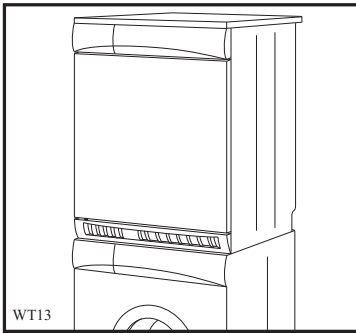

Fig 10

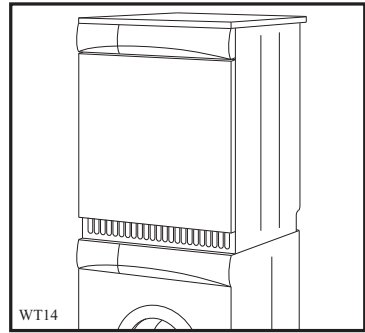

Fig 11

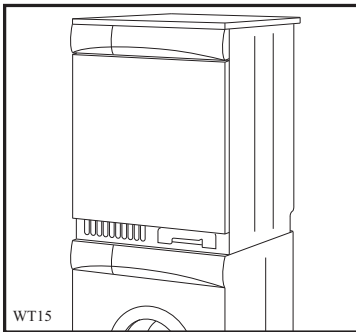

Fig 12

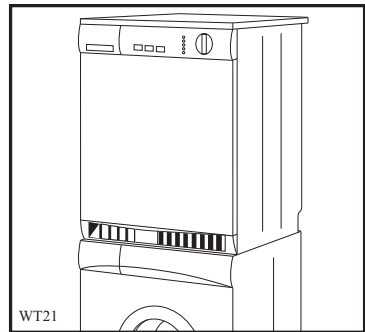
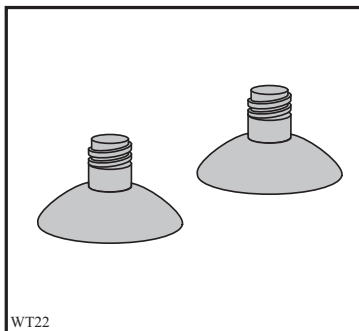

Fig 13



Korte grijs rubberen voetjes (fig. 14) te gebruiken voor de volgende modellen wasdrogers:

- modellen met een luikje in het voetstuk (fig 15, 16 en 17).

Fig 14

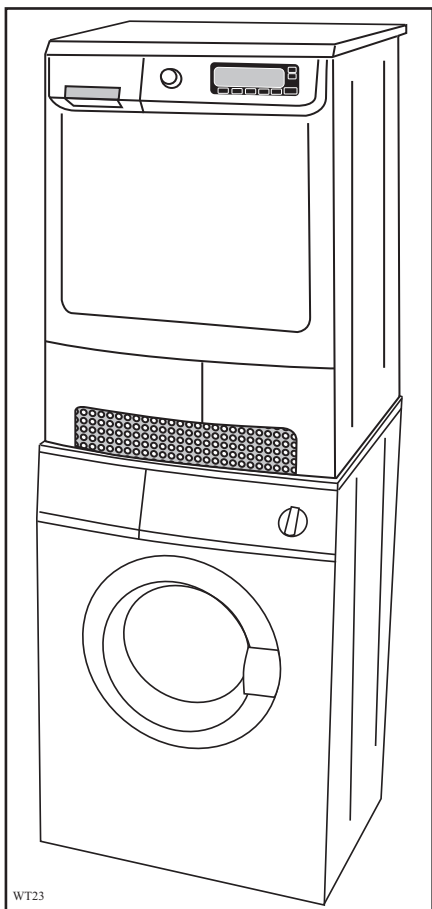

Fig 15

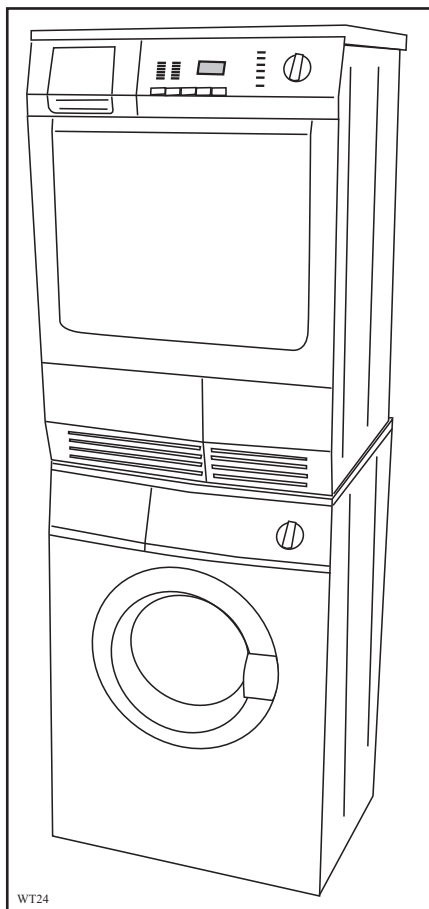
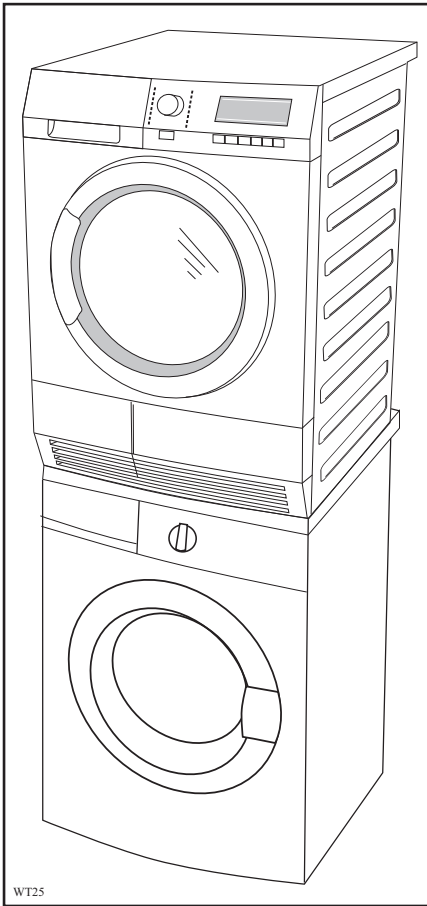

Fig 16



WT25

Fig 17

Kit per il montaggio in colonna di lavatrice ed essiccatore

La costruzione del kit colonna per lavatrice ed essiccatore per economia di spazio e' possibile su tutte le lavatrici a carica frontale aventi una larghezza di 60 cm e una profondita' che va da 55 a 60 cm.

Operazioni da eseguire:

- Mettere l'essiccatore su lato destro facendo attenzione che il mobile non venga danneggiato.
- Estrarre i piedini anteriori (figura 1) e sostituirli con i relativi piedini di gomma (figura 1 a).

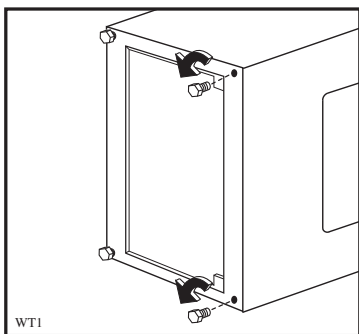

Fig 1

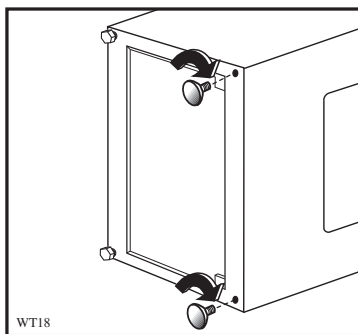

Fig 1a

- Posizionare l'essiccatore sopra la lavatrice e svitare le due viti, in basso a sinistra e a destra, sulla parte posteriore dell'essiccatore.
- Mettere sopra le relative squadrette (figura 2b/3b) a fissarle con le viti (A+B) sia sull'essiccatore che sugli angoli superiori.

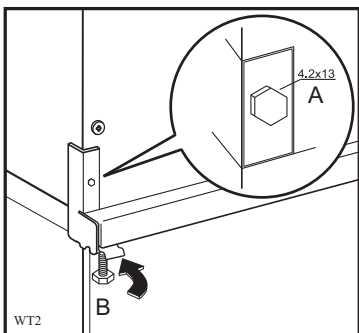

Fig 2 Squadretta piccola

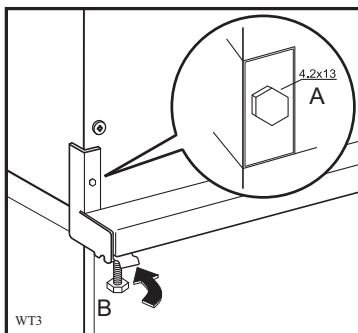

Fig 3 Squadretta grande

viti A = viti autofilettanti 4,2 x 13

viti B = posizione delle viti

Le seguenti foto mostrano con quale squadretta rispettivamente devono essere usati i piedini per i vari modelli di lavatrice ed essiccatore.

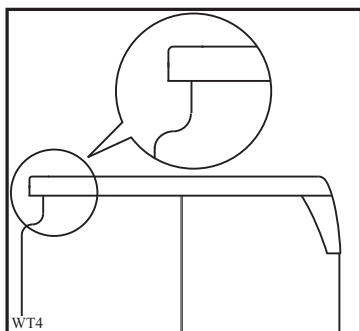

Fig 2a

Lavatrice con angolo superiore poco sporgente.

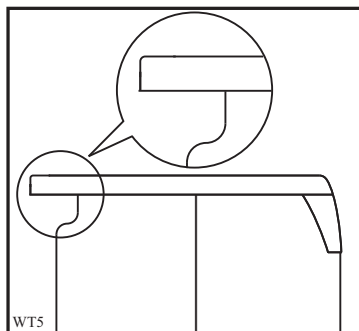

Fig 3a

Lavatrice con angolo superiore molto sporgente.

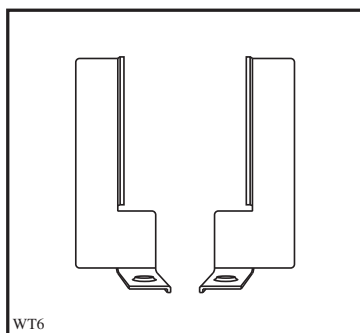

Fig 2b

Piccola squadretta da utilizzare su di una lavatrice che ha l'angolo superiore poco sporgente.

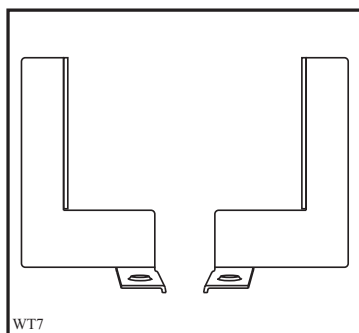

Fig 3b

Grande squadretta da utilizzare su di una lavatrice che ha l'angolo superiore molto sporgente.

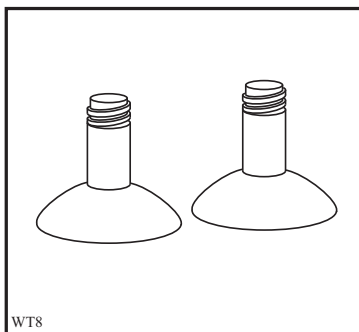

Fig 4

Piedini in gomma lunghi (figura 4) da utilizzare per i seguenti modelli di essiccatori:

- Modello senza zoccolo (fig. 5 e 6);
- Modello con piccola porta nello zoccolo dell'apparecchiatura (fig. 7 e 8).

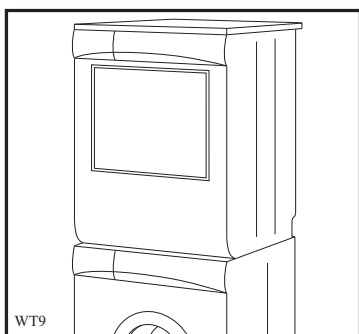

Fig 5

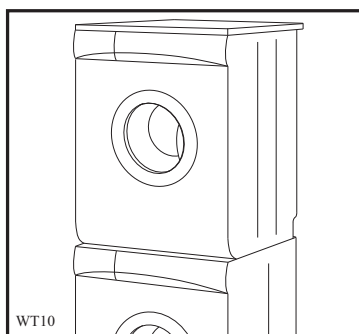

Fig 6

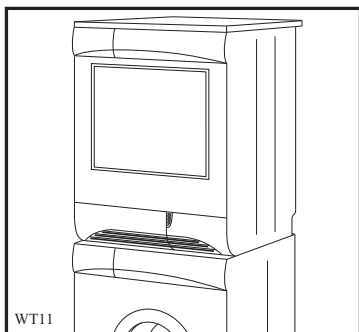

Fig 7

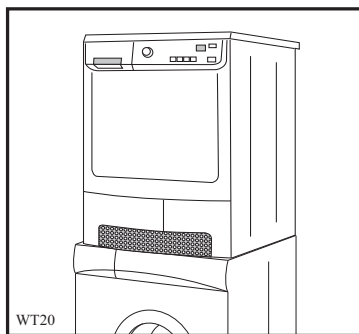

Fig 8

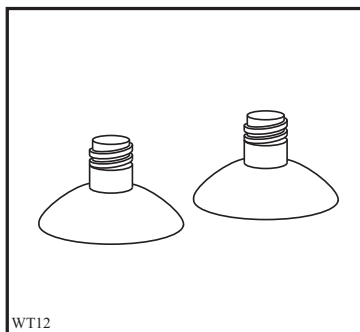

Fig 9

Piedini in gomma corti (figura 9) da utilizzare per i seguenti modelli di essiccatori:

- Modello con zoccolo (figura 10,11, 12 e 13).

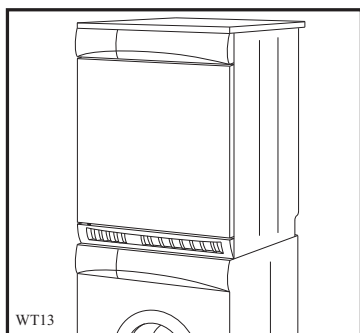

Fig 10

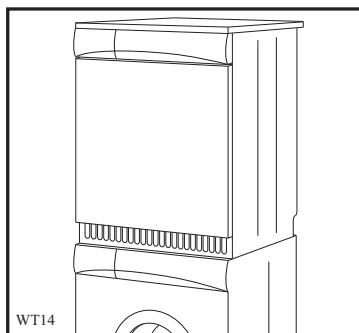

Fig 11

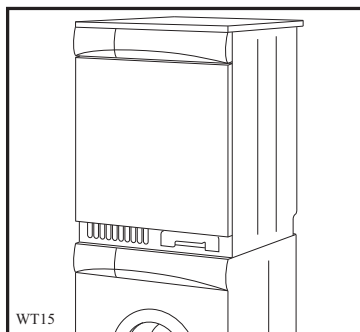

Fig 12

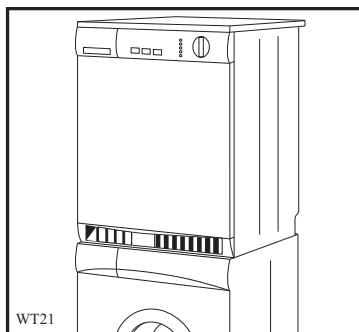

Fig 13

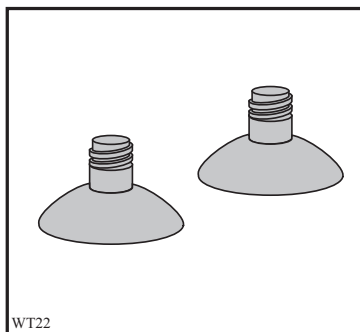

Fig 14

Piedini corti in gomma grigia (figura 14) da utilizzare per i seguenti modelli di essiccatori:

- Modello con piccola porta nello zoccolo dell'apparecchiatura. (fig 15, 16 e 17).

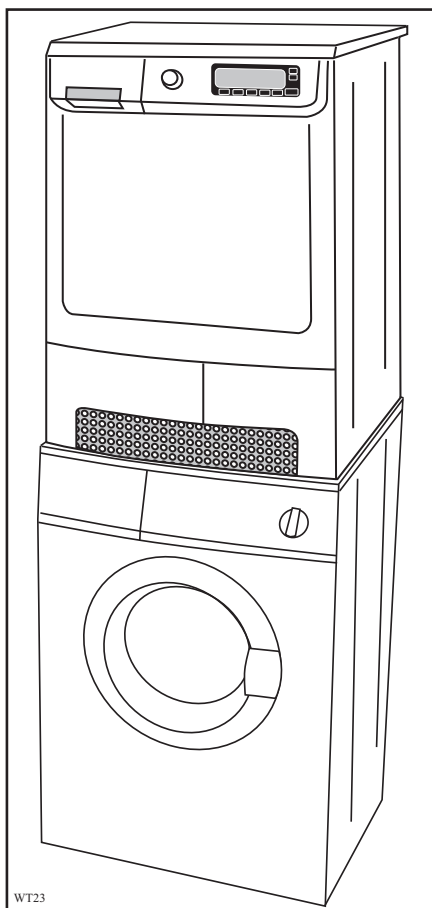

Fig 15

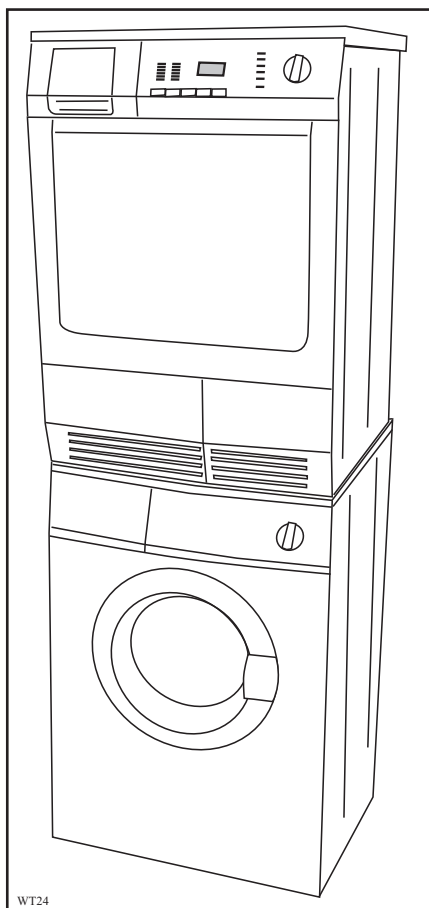
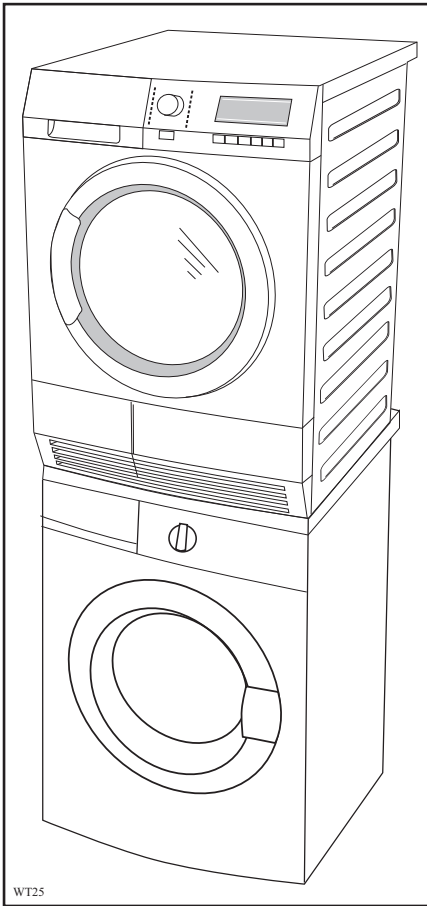

Fig 16



WT25

Fig 17

Kit para la instalación en columna de lavadoras y secadoras

El kit de instalación en columna para reducir el espacio utilizado está disponible para todas las lavadoras con carga frontal de 60 cm de anchura y una profundidad comprendida entre 55 y 60 cm.

Procedimiento:

- Apoyar la secadora en el lado derecho, teniendo cuidado de no dañar la estructura.
- Quitar los pies frontales (fig. 1) y sustituirlos con los pies de goma correspondientes (fig. 1a).

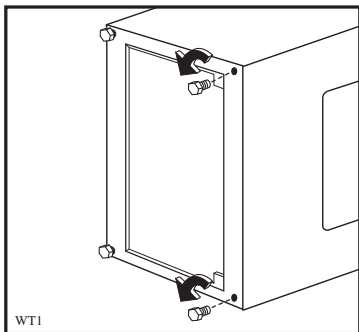

Fig 1

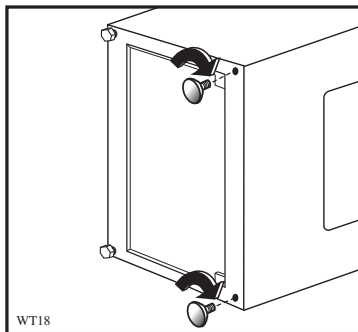

Fig 1a

- Situar la secadora sobre la lavadora y destornillar los 2 tornillos que se encuentran en el lado derecho e izquierdo de la parte trasera de la secadora.
- Instalar las placas metálicas de fijación correspondientes (fig. 2b/3b) y fijarlas mediante los tornillos suministrados (A+B), tanto en la secadora como en las aristas superiores.

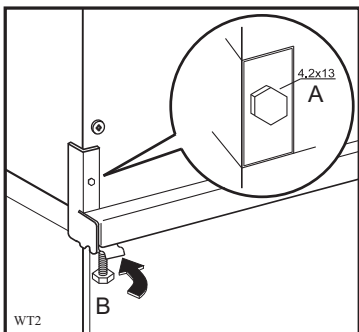

Fig 2 Placa metálica de fijación pequeña

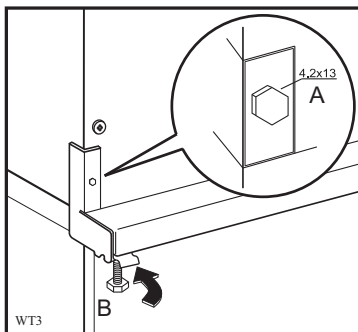

Fig 3 Placa metálica de fijación grande

Tornillos A = tornillos autorroscantes 4,2x13

Tornillos B = posición de los tornillos

Las figuras siguientes representan el tipo de placa metálica a utilizar según los pies para los diferentes modelos de lavadora y secadora.

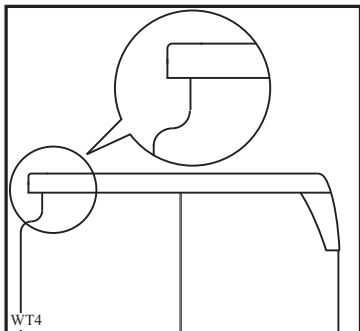

Fig 2a
Lavadoras con arista superior que resalta poco.

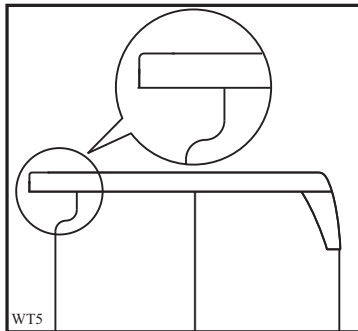

Fig 3a
Lavadoras con arista superior que resalta mucho.

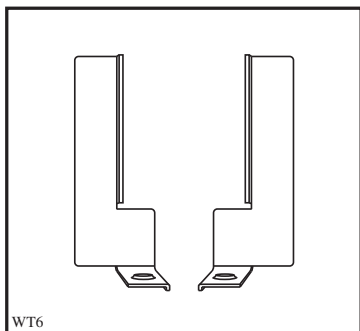

Fig 2b
Placa metálica de fijación pequeña a utilizar para lavadoras con arista superior que resalta poco.

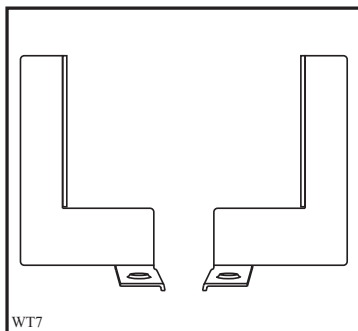

Fig 3b
Placa metálica de fijación grande a utilizar para lavadoras con arista superior que resalta mucho.

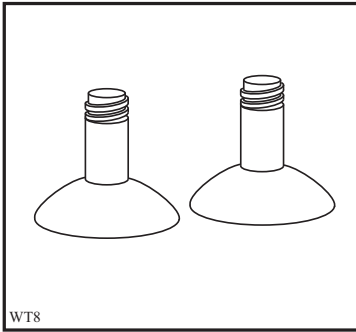

Fig 4

Pies de goma largos (fig. 4) a utilizar para los siguientes modelos de secadoras:

- modelos sin zócalo (fig. 5 y 6);
- modelos con tapa en el zócalo (fig. 7 y 8).

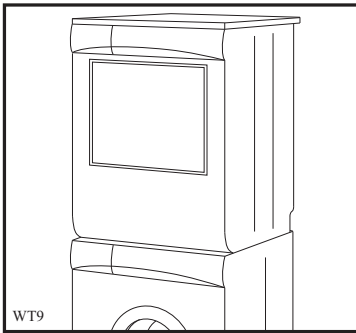

Fig 5

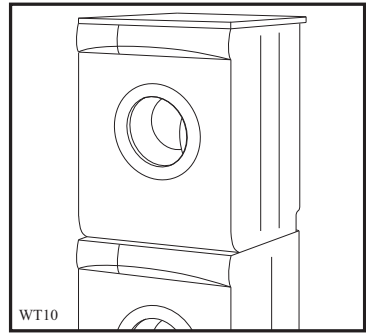

Fig 6

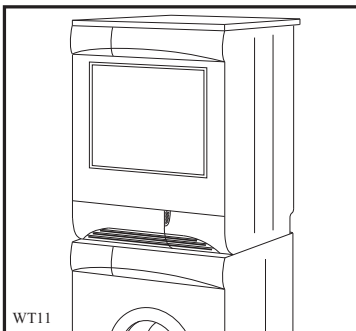

Fig 7

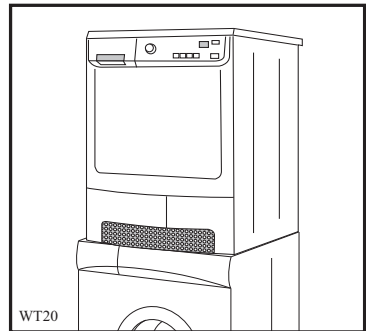
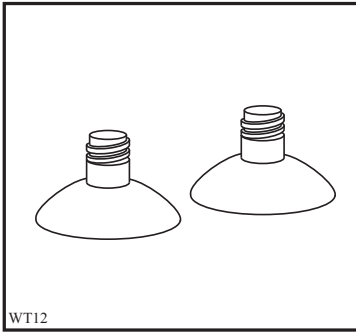

Fig 8



Pies de goma cortos (fig. 9) a utilizar para los siguientes modelos de secadoras:

- Modelos con zócalo (fig. 10, 11, 12 y 13).

Fig 9

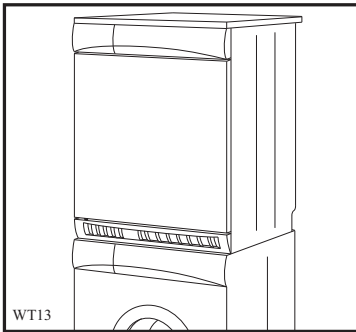

Fig 10

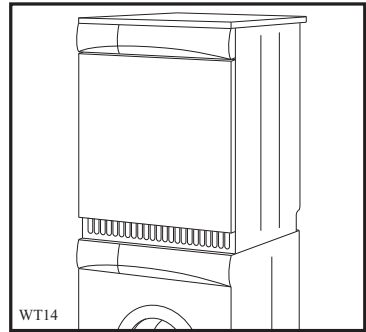

Fig 11

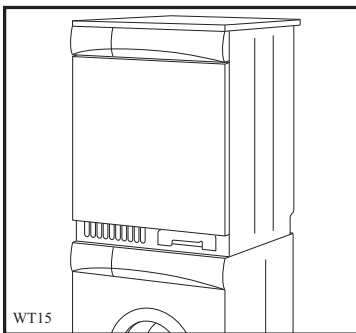

Fig 12

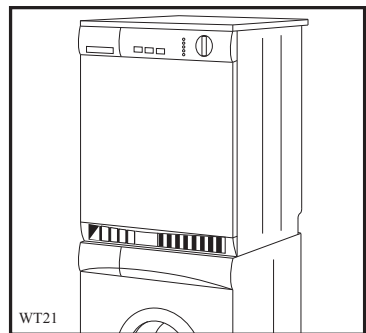

Fig 13

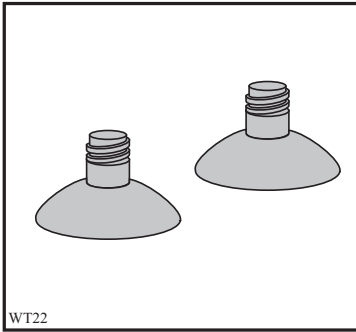

Fig 14

Pies gris de goma cortos (fig. 14) a utilizar para los siguientes modelos de secadoras:

- modelos con tapa en el zócalo (fig 15, 16 y 17).

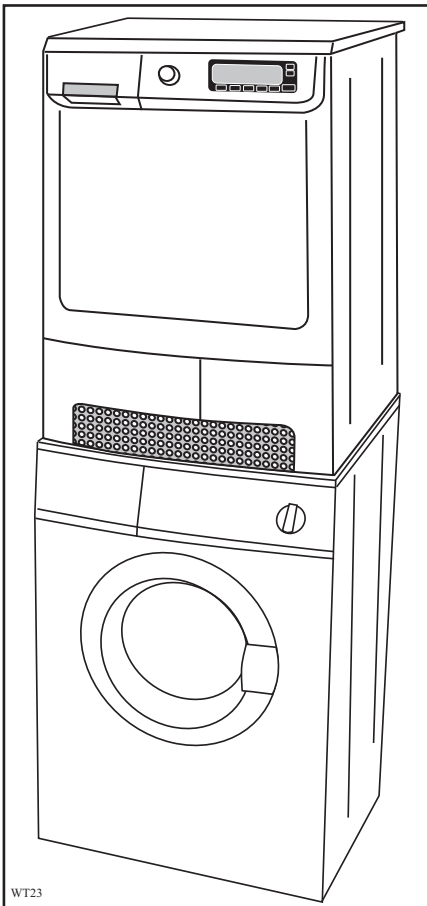

Fig 15

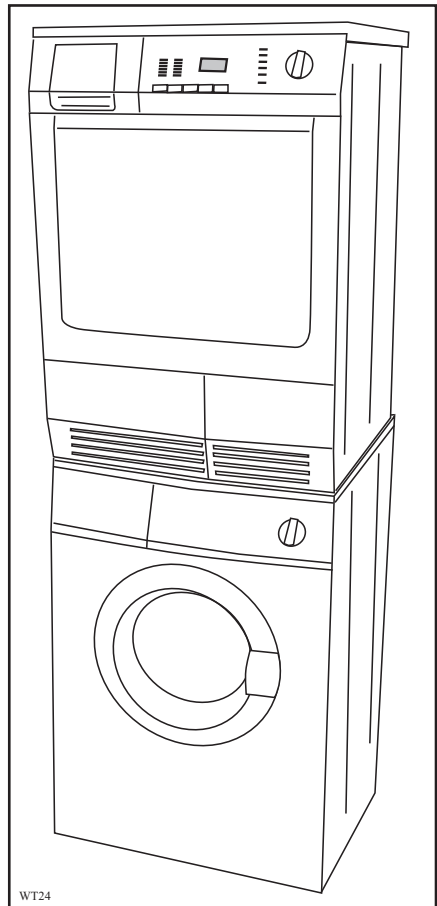
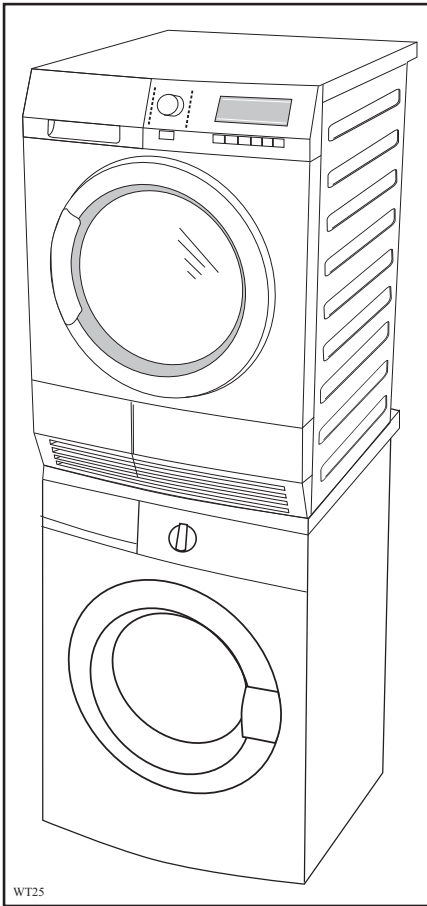

Fig 16



WT25

Fig 17

Kit para a montagem em coluna de máquinas de lavar e secar roupa

O kit de montagem em coluna para reduzir o espaço utilizado é disponível para todas as máquinas de lavar roupa com carregamento frontal com 60 cm de largura e uma profundidade incluída entre 55 e 60 cm.

Procedimento:

- Apoiar a máquina secadora no lado direito prestando atenção para não danificar a estrutura.
- Remover os pés frontais (fig. 1) e substituí-los com os pés de borracha (fig. 1a).

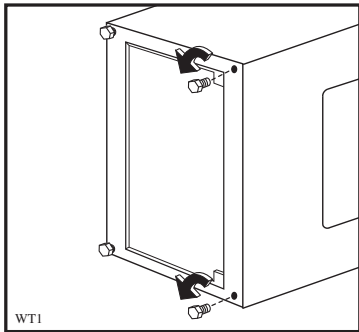

Fig 1

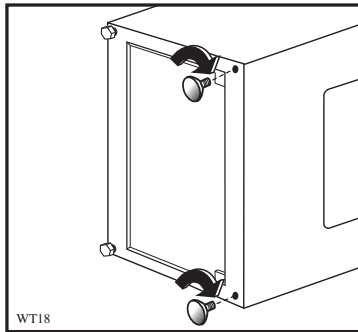

Fig 1a

- Posicionar a máquina secadora encima da máquina de lavar roupas e desparafusar os dois parafusos que se encontram do lado direito e esquerdo da parte traseira da máquina secadora.
- Montar as correspondentes chapas metálicas de fixação (fig. 2b/3b) e fixá-las com os parafusos fornecidos (A+B) tanto na máquina secadora quanto nas arestas superiores.

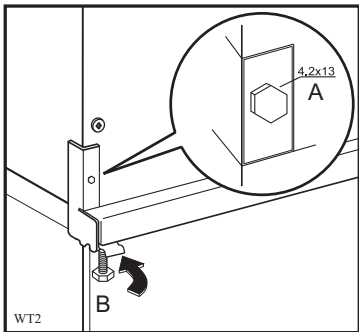

Fig 2 Chapa metálica de fixação pequena

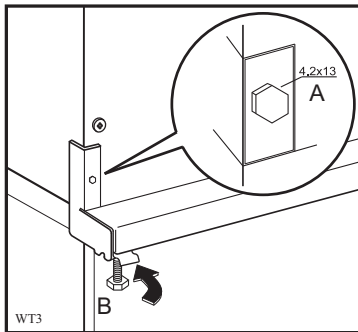

Fig 3 Chapa metálica de fixação grande

Parafusos A = parafusos auto-roscentes 4,2x13

Parafusos B = posicionamento parafusos

As figuras abaixo mostram o tipo de chapa metálica que deve ser utilizado conforme os pés para os vários modelos de máquina de lavar e secar roupas.

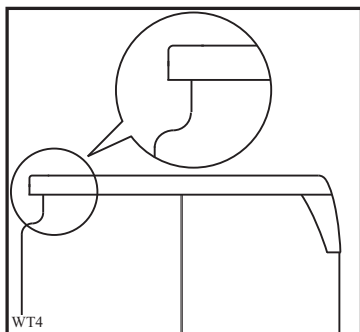

Fig 2a
Máquinas de lavar com aresta superior pouco saliente.

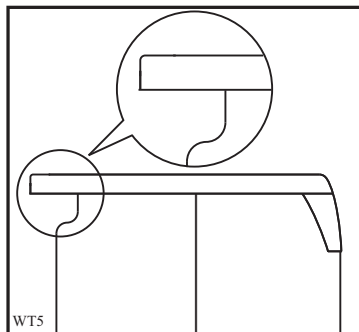

Fig 3a
Máquinas de lavar com aresta superior muito saliente.

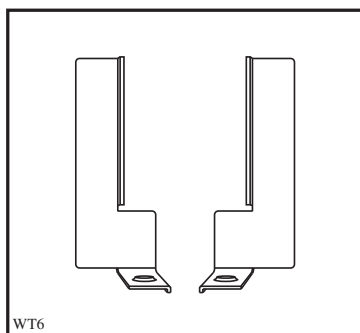

Fig 2b
Chapa metálica de fixação pequena a ser utilizada para máquinas de lavar com aresta pouco saliente.

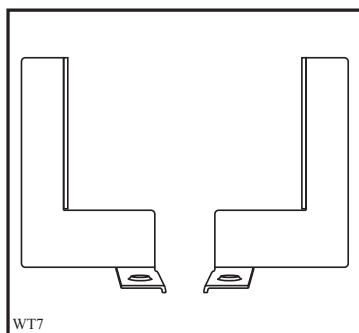

Fig 3b
Chapa metálica de fixação pequena a ser utilizada para máquinas de lavar com aresta muito saliente.

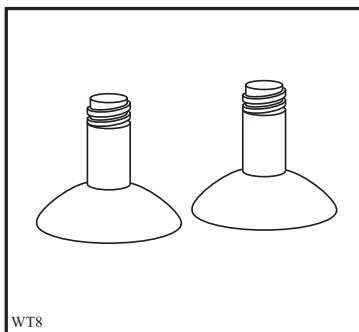

Fig 4

Pés de borracha compridos (fig. 4) a serem utilizados com os seguintes modelos de máquinas secadoras:

- modelos sem cobertura de base (fig. 5 e 6);
- modelos com portinhola na cobertura de base (fig. 7 e 8).

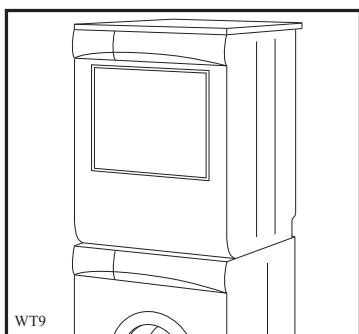

Fig 5

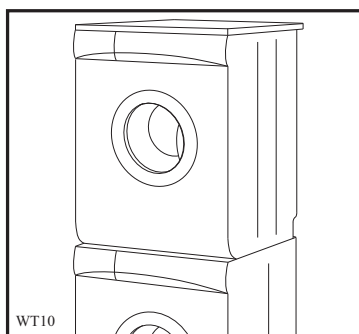

Fig 6

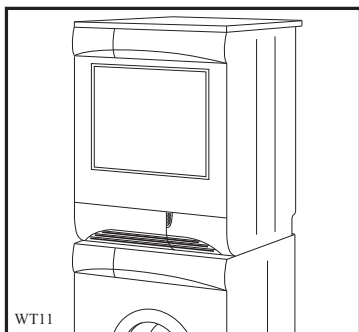

Fig 7

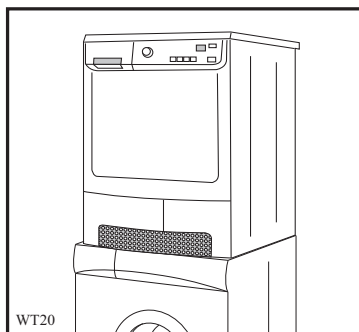

Fig 8

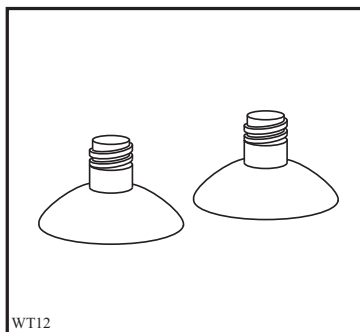

Fig 9

Pés de borracha curtos (fig. 9) a serem utilizados com os seguintes modelos de máquinas secadoras:

- Modelos com cobertura de base (fig. 10, 11, 12 e 13).

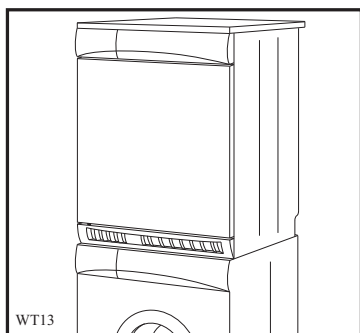

Fig 10

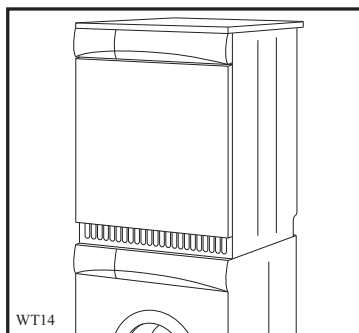

Fig 11

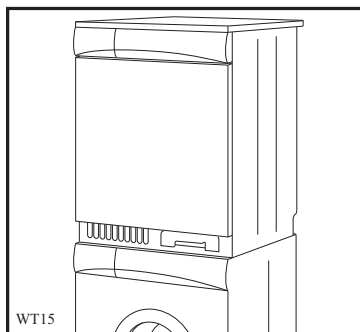

Fig 12

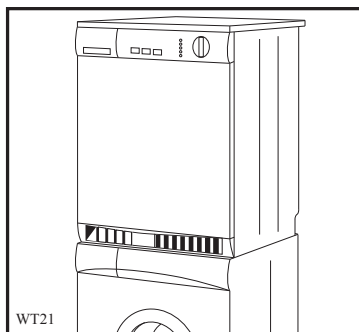

Fig 13

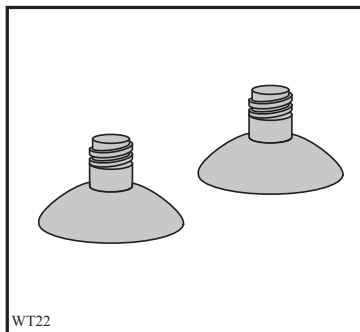

Fig 14

Pés cinzento de borracha curtos (fig. 14) a serem utilizados com os seguintes modelos de máquinas secadoras:

- modelos com portinhola na cobertura de base (fig 15, 16 e 17).

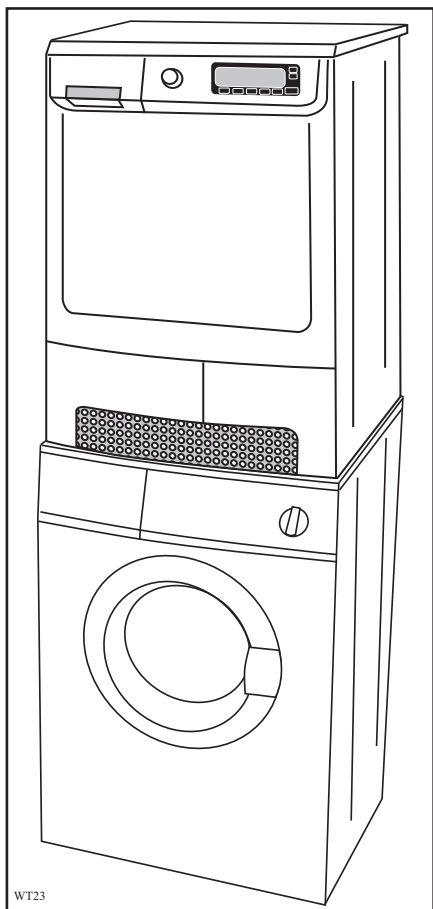

Fig 15

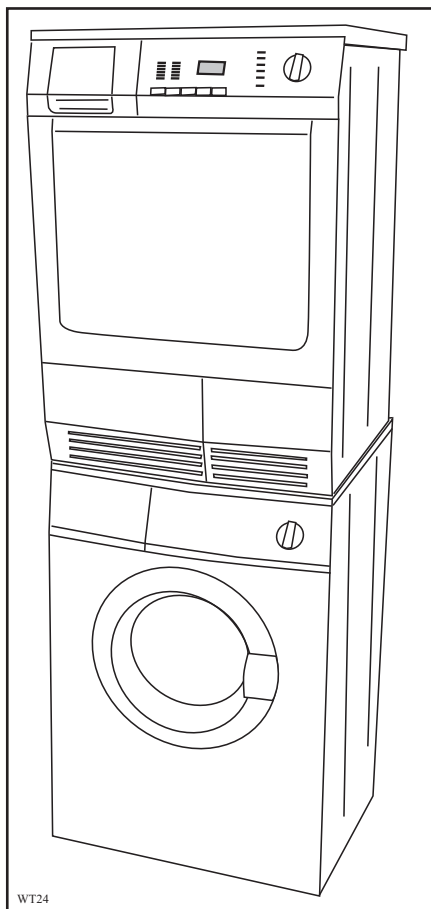

Fig 16

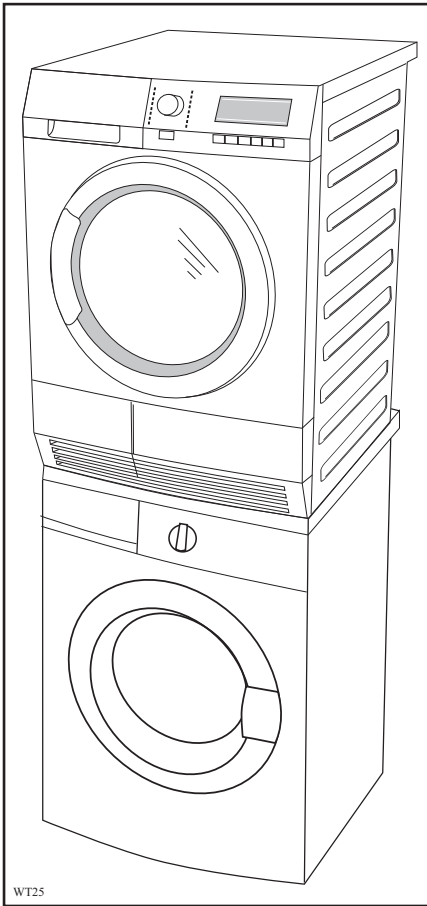

Fig 17

Udstyr til montering i vaskesøjle

Udstyret til montering i vaskesøjle for at spare plads findes til alle frontbetjente vaskemaskiner (bredde 60 cm; dybde 55-60 cm).

Fremgangsmåde:

- Anbring tørretumbleren på højre side. Vær forsigtig for at undgå beskadigelse af strukturen.
- Fjern de forreste fødder (fig. 1) og udskift dem med gummifødderne (fig. 1a).

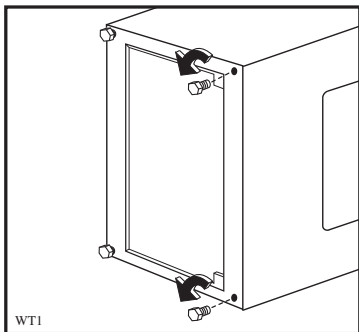

Fig 1

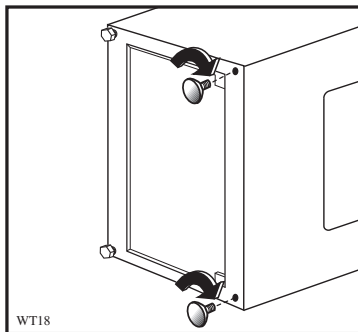

Fig 1a

- Anbring tørretumbleren på vaskemaskinen og løsn de to skruer på højre og venstre side bag på tørretumbleren.
- Montér låsepladerne af metal (fig. 2b/3b) og blokér dem på tørretumbleren og på vaskemaskinens øverste hjørner ved hjælp af de medfølgende skruer (A+B).

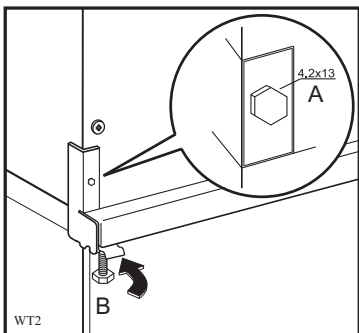

Fig 2 Lille låseplade af metal

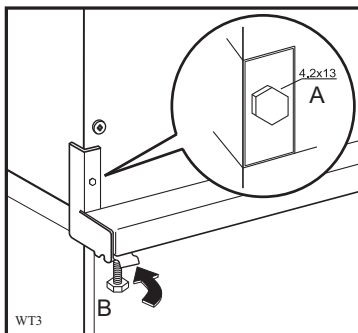

Fig 3 Stor låseplade af metal

Skruer A = Selvskærende skruer 4,2x13

Skruer B = Placering af skruer

Nedenstående figurer viser, hvilken type låseplade af metal, der skal anvendes afhængigt af fødderne på de forskellige vaskemaskine- og tørretumblermodeller.

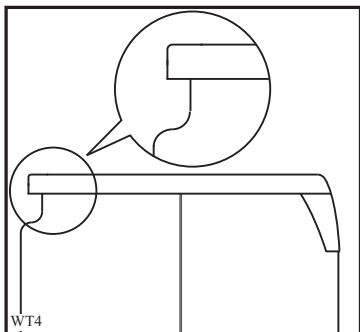

Fig 2a
Vaskemaskiner med lille fremspring på øverste hjørne.

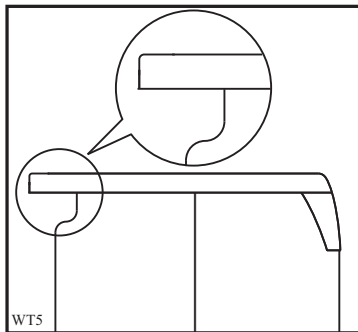

Fig 3a
Vaskemaskiner med stort fremspring på øverste hjørne.

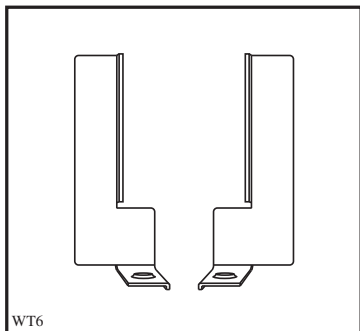

Fig 2b
Lille låseplade af metal til brug på vaskemaskiner med lille fremspring på øverste hjørne.

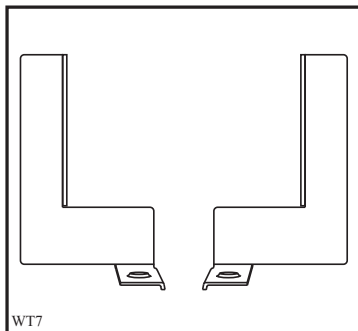

Fig 3b
Stor låseplade af metal til brug på vaskemaskiner med stort fremspring på øverste hjørne.

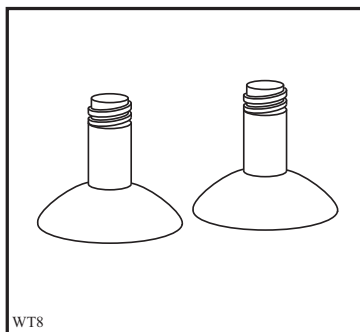

Fig 4

Lange gummifødder (fig. 4) til brug på følgende tørretumblermodeller:

- Modeller uden sokkel (fig. 5 og 6);
- Modeller med låge på sokkel (fig. 7 og 8).

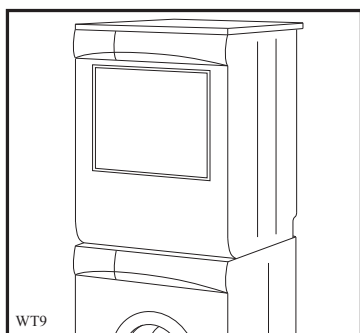

Fig 5

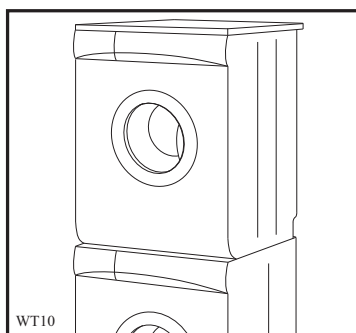

Fig 6

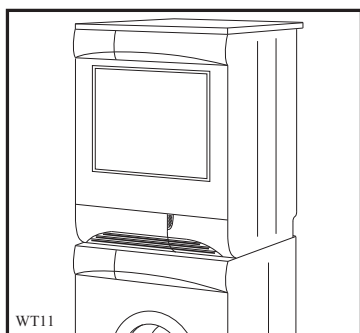

Fig 7

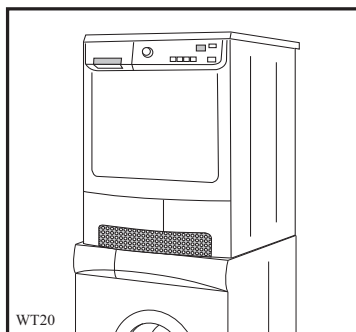

Fig 8

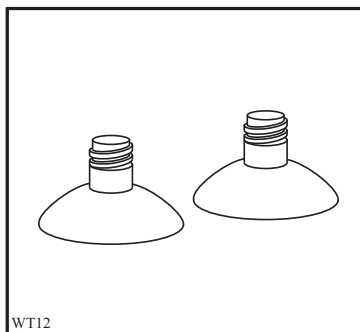

Fig 9

Korte gummifødder (fig. 9) til brug på følgende tørretumblermodeller:

- Modeller med sokkel (fig. 10, 11, 12 og 13).

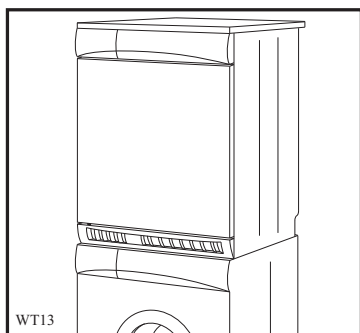

Fig 10

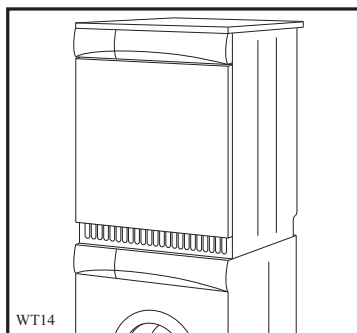

Fig 11

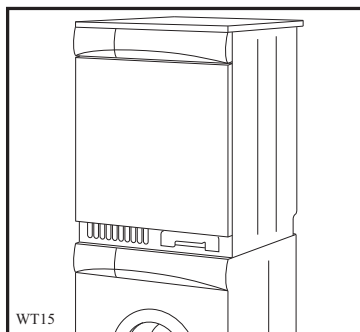

Fig 12

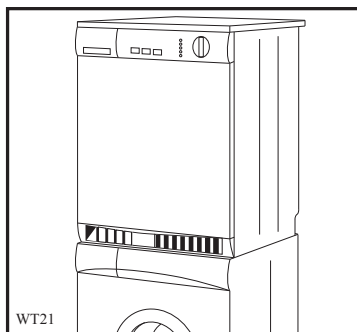
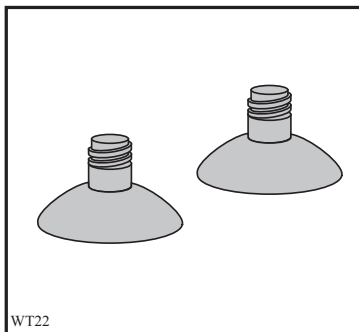

Fig 13



WT22

Fig 14

Grat korte gummifødder (fig. 14) til brug på følgende tørretumblermodeller:

- Modeller med låge på sokkel (fig 15, 16 og 17).

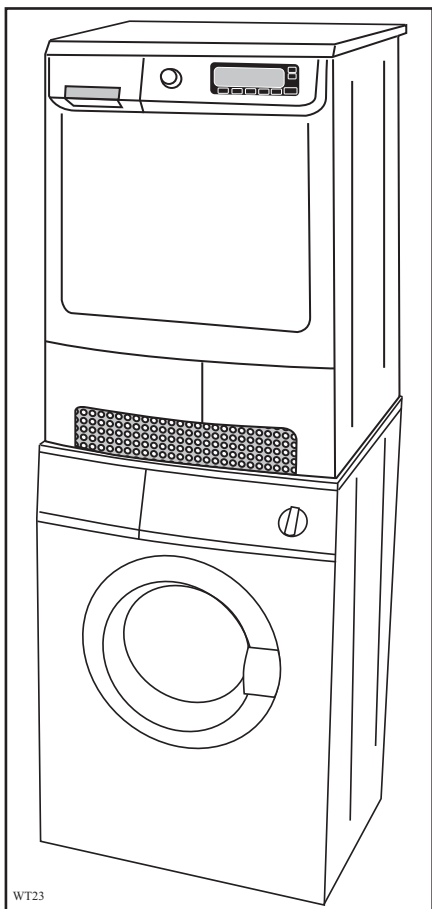

WT23

Fig 15

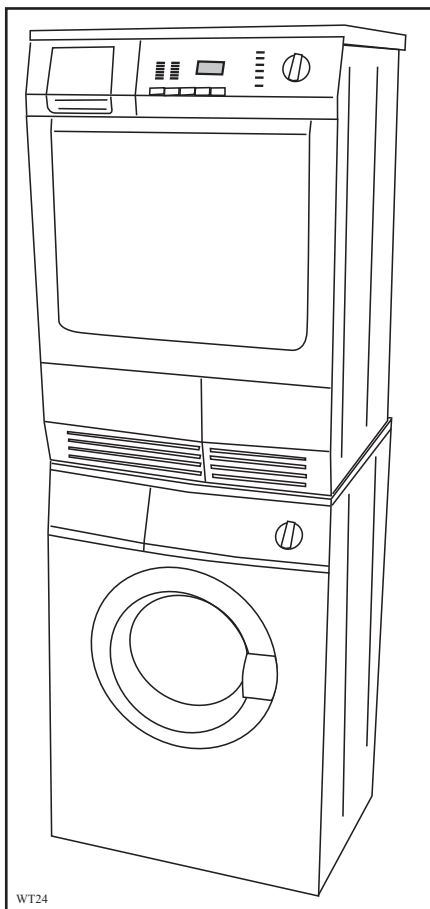

WT24

Fig 16

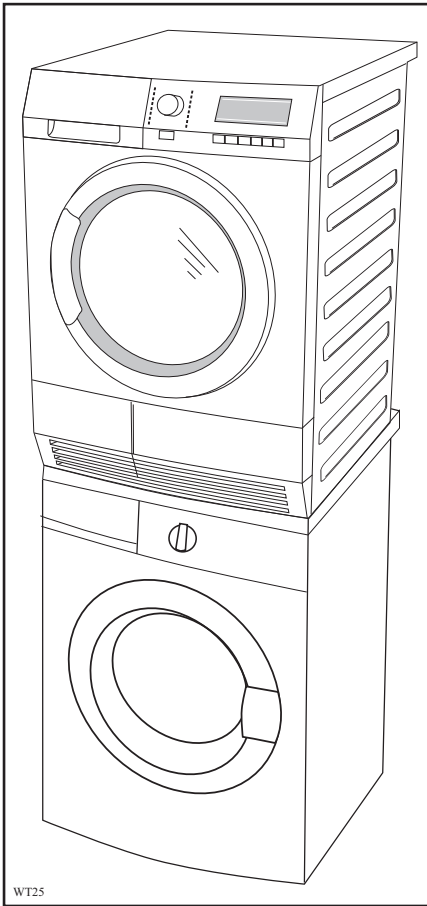

WT25

Fig 17

Sett til vaskesøyle

Settet til vaskesøyle er nyttig når du har plassmangel og er tilgjengelig til alle frontmatete vaskemaskiner. Vaskemaskinens bredde må være på 60 cm og dybden må være mellom 55 og 60 cm.

Fremgangsmåte:

- Plasser tørketrommelen på høyre side og pass på at du ikke skader strukturen.
- Fjern føttene fremme (fig. 1) og skift dem ut med de tilsvarende gummiføttene (fig. 1a).

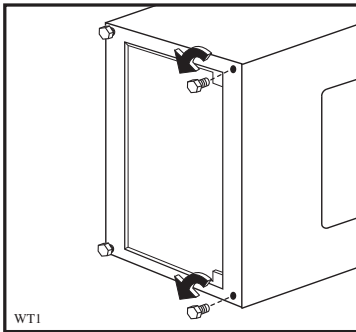

Fig 1

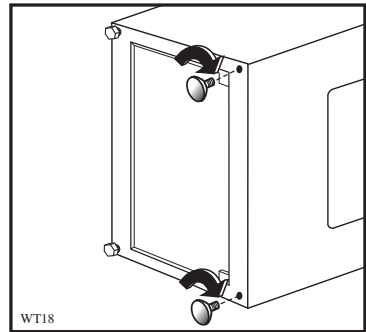

Fig 1a

- Plasser tørketrommelen oppå vaskemaskinen og skru løs de to skruene på høyre og venstre side på baksiden av tørketrommelen.
- Monter metallfesteplatene (fig. 2b/3b) og fest dem med skruene som følger med (A+B) både på tørketrommelen og på vaskemaskinens øverste kanter.

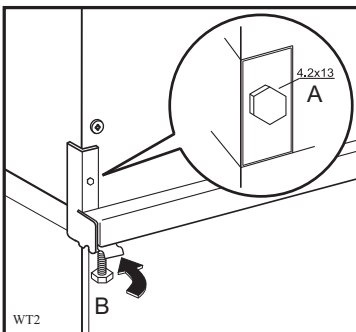

Fig 2 Liten metallfesteplate

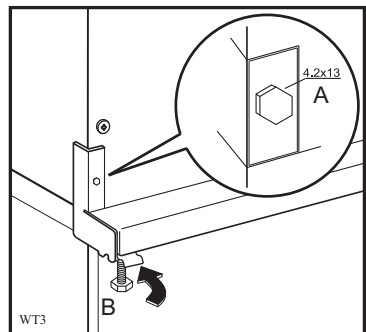

Fig 3 Stor metallfesteplate

Skruer A = Selvgjengende skruer 4,2x13

Skruer B = Plassering av skruene

Figurene som følger viser type metallfesteplater som skal brukes avhengig av føttene til de forskjellige vaskemaskin- og tørketrommelmodellene.

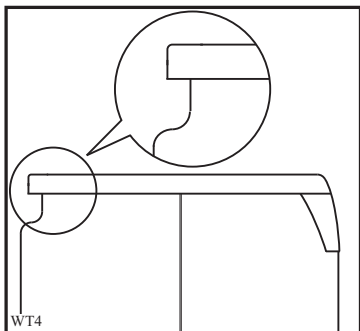

Fig 2a
Vaskemaskiner med den øverste kanten som stikker lite ut.

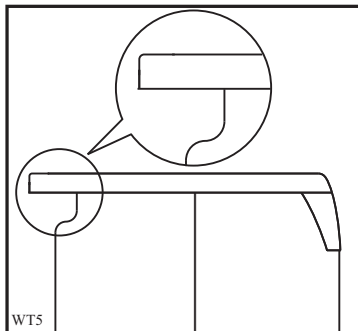

Fig 3a
Vaskemaskiner med den øverste kanten som stikker mye ut.

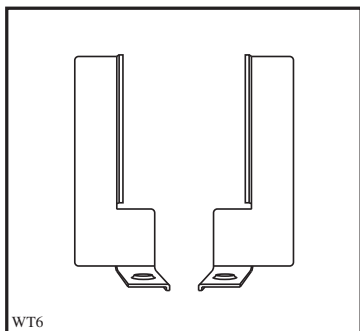

Fig 2b
Liten metallfesteplate som skal brukes til vaskemaskiner med den øverste kanten som stikker lite ut.

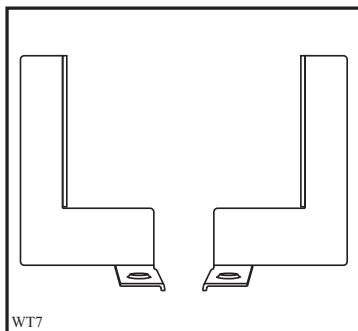
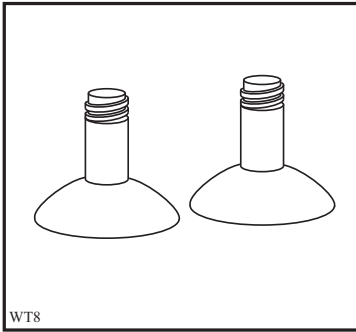

Fig 3b
Stor metallfesteplate som skal brukes til vaskemaskiner med den øverste kanten som stikker mye ut.



Lange gummføtter (fig. 4) som skal brukes til følgende tørketrommelmodeller:

- Modeller uten sokkel (fig. 5 og 6);
- Modeller med liten luke på sokkelen (fig. 7 og 8).

Fig 4

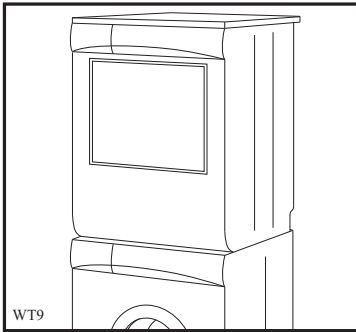

Fig 5

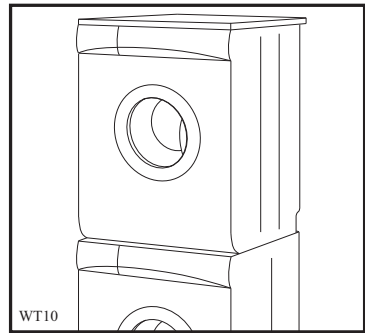

Fig 6

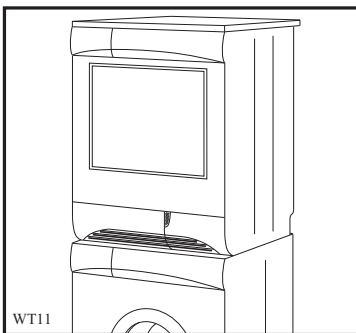

Fig 7

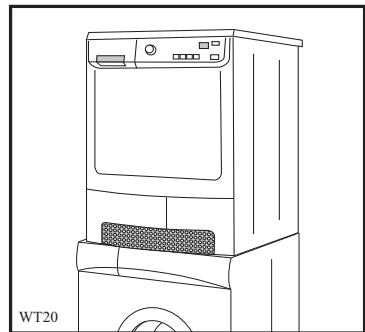
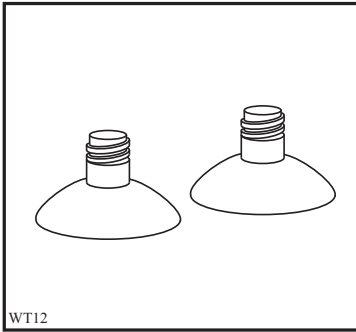

Fig 8



Korte gummiføtter (fig. 9) som skal brukes til følgende tørketrommelmodeller:

- Modeller med sokkel (fig. 10, 11, 12 og 13).

Fig 9

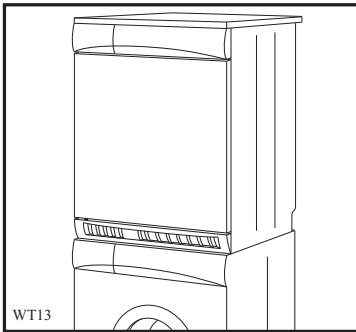

Fig 10

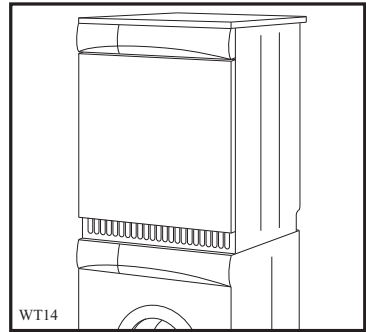

Fig 11

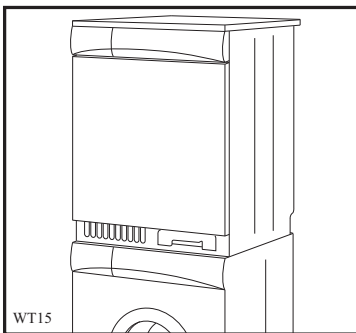

Fig 12

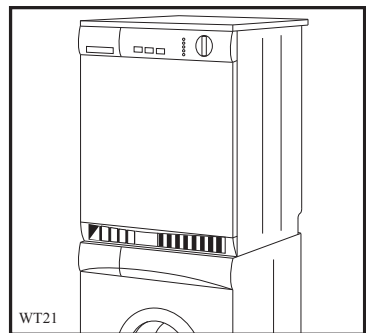

Fig 13

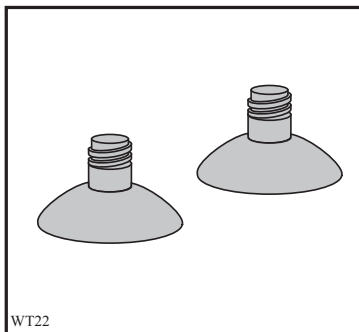

Fig 14

Grå korte gummiføtter (fig. 14) som skal brukes til følgende tørketrommelmodeller:

- Modeller med liten luke på sokkelen (fig 15, 16 og 17).

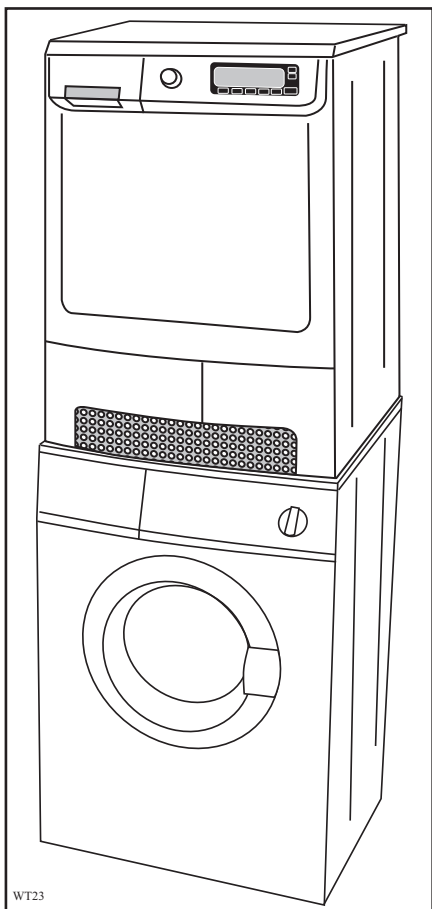

Fig 15

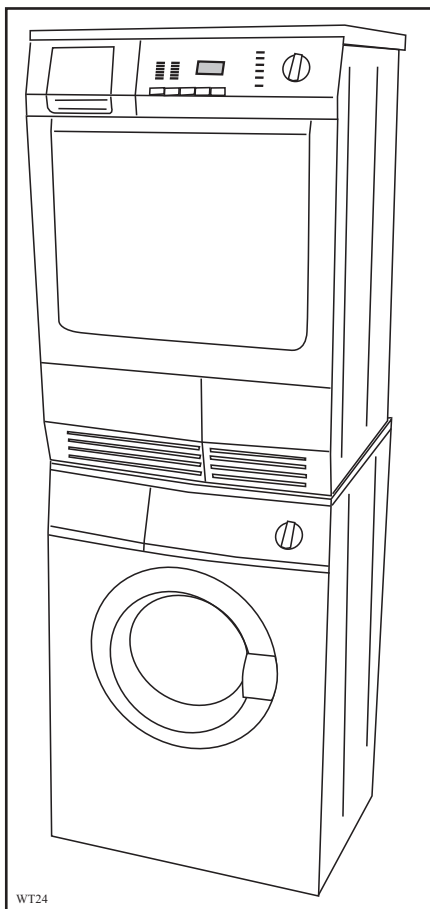
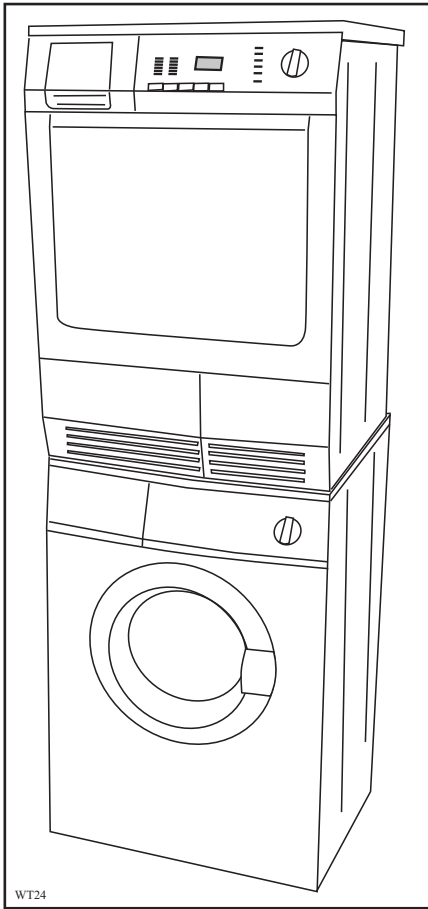

Fig 16



WT24

Fig 17

Monteringsats för tvättpelare

Monteringsatsen för tvättpelare, som används för att spara utrymme, går att få till samtliga frontmatade tvättmaskiner med bredd på 60 cm och djup på 55-60 cm.

Gör så här:

- Lägg ned torktumlaren på höger sida. Var försiktig så att du inte skadar stommen.
- Ta av de främre fötterna (fig. 1) och byt ut dem mot motsvarande fötter av gummi (fig. 1a).

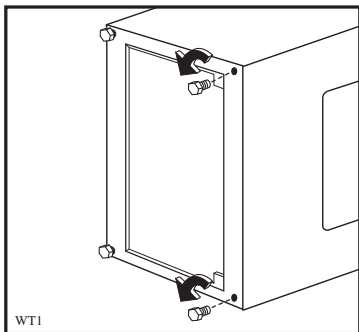

Fig 1

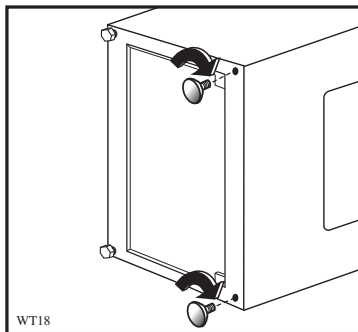

Fig 1a

- Placera torktumlaren ovanpå tvättmaskinen och skruva loss de två skruvarna till höger resp. vänster på torktumlarens bakstycke.
- Montera motsvarande fästbrickor av metall (fig. 2b/3b) och skruva fast dem både i torktumlaren och i överkanten på tvättmaskinen med medföljande skruvar (A+B).

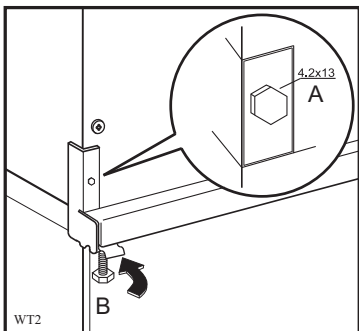

Fig 2 Liten fästbricka av metall

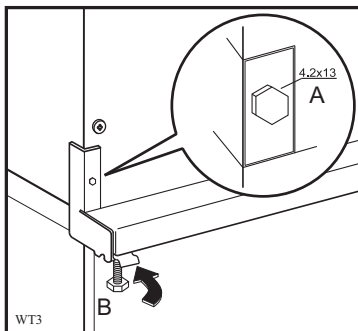

Fig 3 Stor fästbricka av metall

Skravar A = Självgående skruvar 4,2 x 13

Skravar B = Placering av skruvar

I följande figurer visas vilken typ av metallbricka som ska användas beroende på fötterna på de olika tvättmaskins- och torktumlarmodellerna.

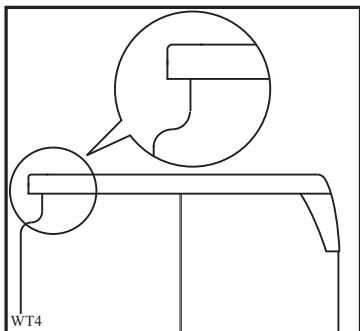

Fig 2a
Tvättmaskiner med lite utstickande överkant.

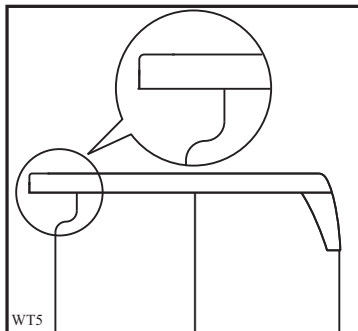

Fig 3a
Tvättmaskiner med mycket utstickande överkant.

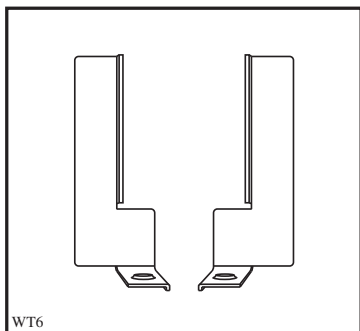

Fig 2b
Liten fästbricka av metall som ska användas för tvättmaskiner med lite utstickande överkant.

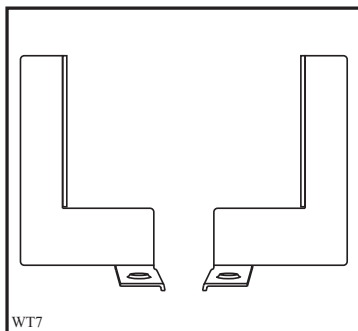

Fig 3b
Stor fästbricka av metall som ska användas för tvättmaskiner med mycket utstickande överkant.

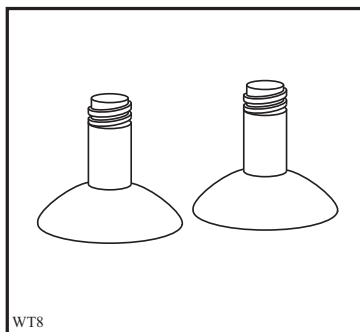

Fig 4

Höga gummifötter (fig. 4) som ska användas för följande tvättmaskinsmodeller:

- Modeller utan sockel (fig. 5 och 6);
- Modeller med lucka på sockeln (fig. 7 och 8).

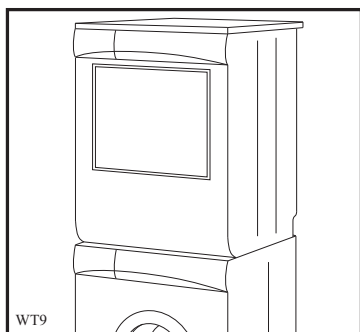

Fig 5

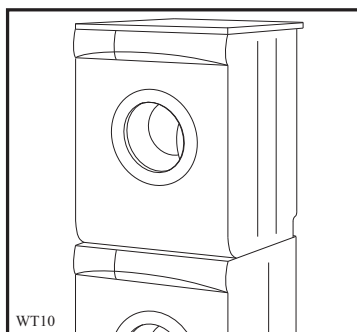

Fig 6

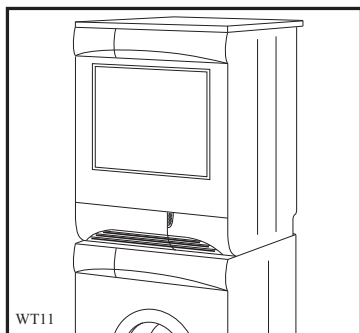

Fig 7

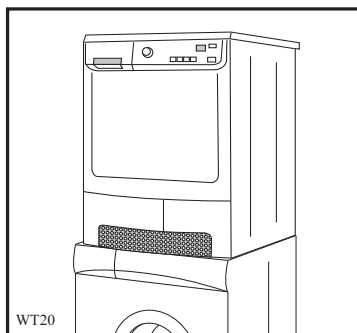

Fig 8

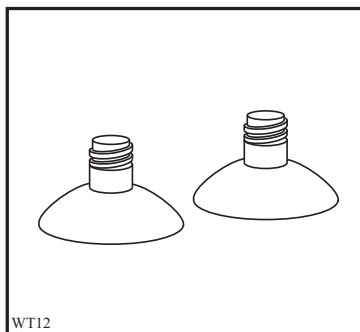

Fig 9

Låga gummfötter (fig. 9) som ska användas för följande tvättmaskinsmodeller:

- Modeller med sockel (fig. 9, 10 och 11).

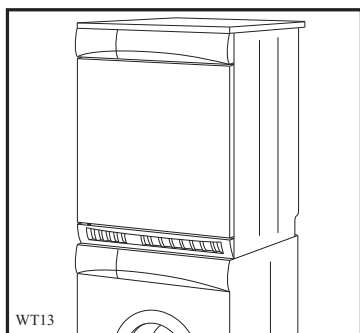

Fig 10

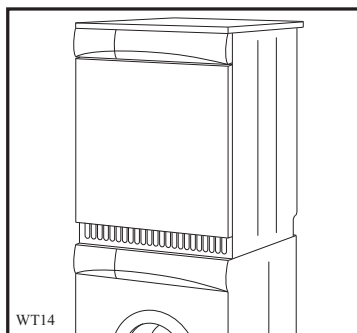

Fig 11

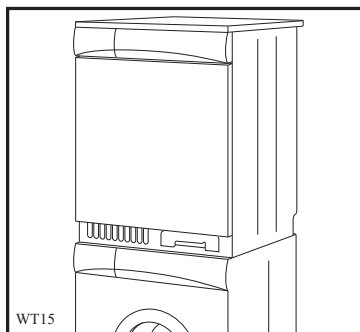

Fig 12

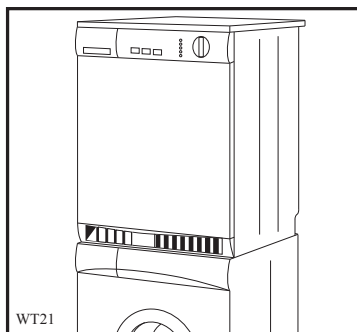
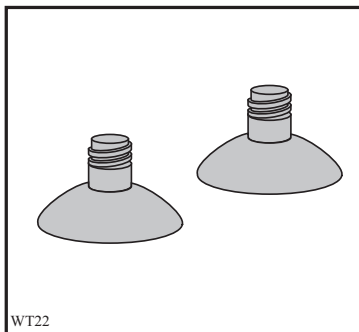

Fig 13



Gråa låga gummifötter (fig. 14) som ska användas för följande tvättmaskinsmodeller:

- Modeller med lucka på sockeln (fig 15, 16 og 17).

Fig 14

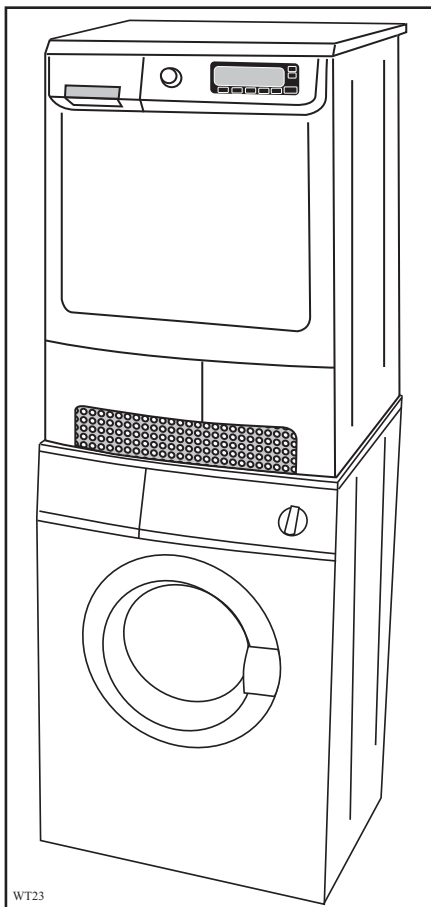

Fig 15

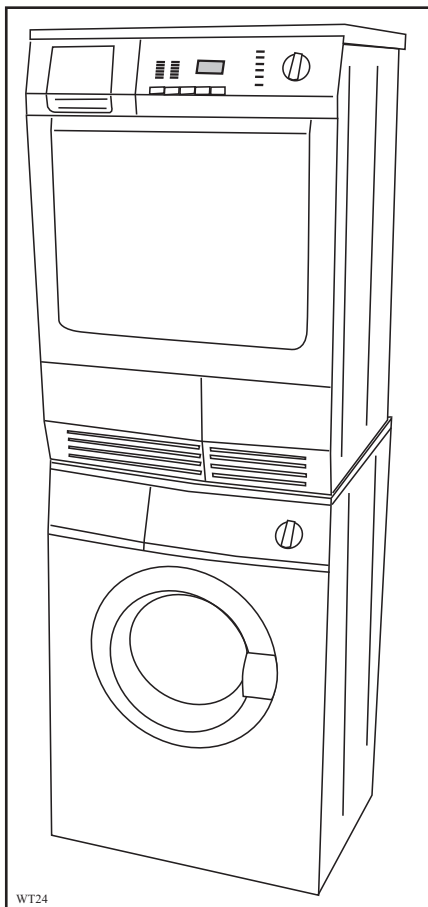

Fig 16

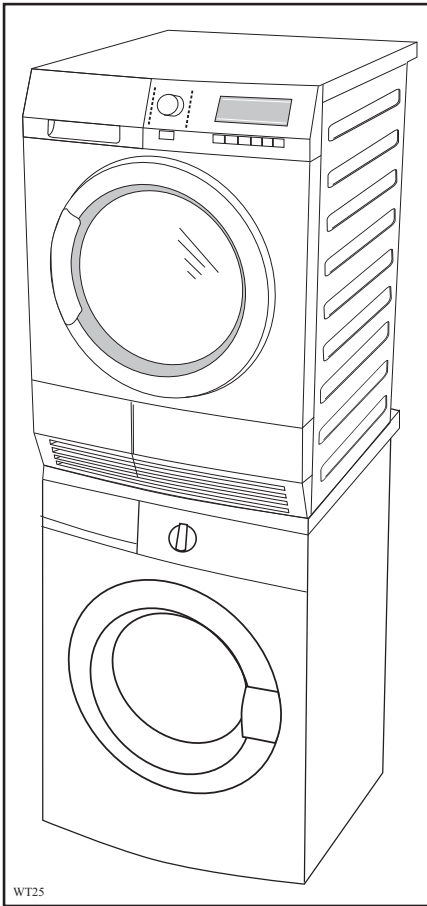

Fig 17

Pesukoneen ja kuivausrummun torniin asennussarja

Pesutornin asennussarjalla säästetään tilaa. Se on saatavilla kaikille edestä täytettäville pesukoneille, joiden leveys on 60 cm ja syvyys 55 - 60 cm.

Toimenpiteet:

- Aseta kuivausrumpu pesukoneen oikealle puolelle. Varo, ettet vahingoita sen rakennetta.
- Poista etujalat (kuva 1) ja vaihda ne vastaaviin kumijalkoihin (kuva 1a).

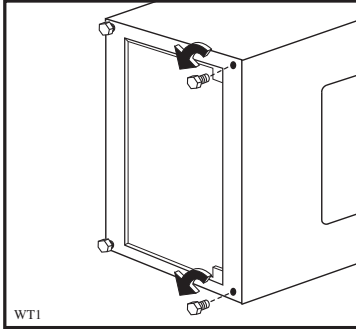

Kuva 1

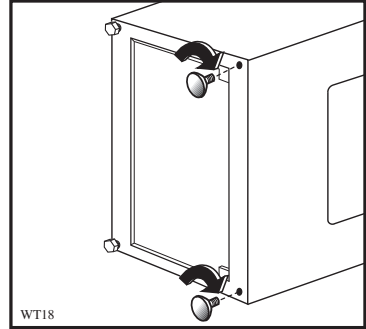

Kuva 1a

- Aseta kuivausrumpu pesukoneen päälle ja ruuvaa auki 2 ruuvia, jotka sijaitsevat kuivausrummun takaseinän oikealla ja vasemmalla puolella.
- Asenna metallikiinnityslevyt (kuva 2b/3b) ja kiinnitä ne ohessa toimitetuilla ruuveilla (A+B) sekä kuivausrumpuun että pesukoneen yläkulmiin.

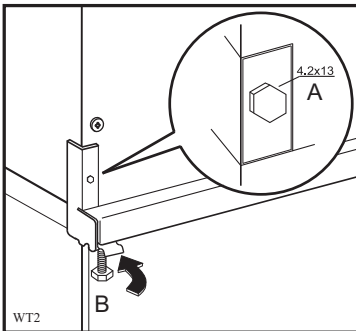

Kuva 2 Pieni metallikiinnityslevy

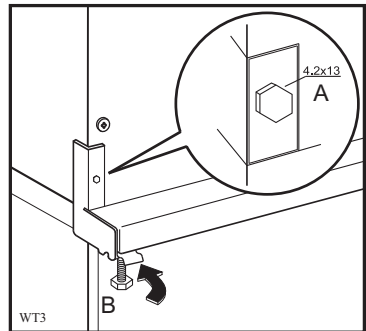

Kuva 3 Suuri metallikiinnityslevy

Ruuvit A = itsekierteittävät ruuvit 4,2 x 13

Ruuvit B = ruuvien asetus

Seuraavissa kuvissa näytetään käytettävän metallikiinnityslevyn tyyppi ja pesukoneiden ja kuivausrumpujen eri malleille tarkoitetut jalat.

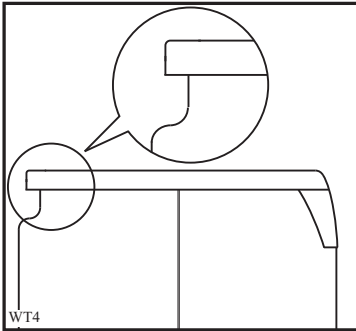

Kuva 2a
Pesukoneet, joiden yläkulma on hieman ulkoneva.

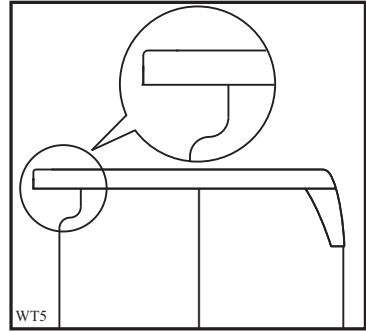

Kuva 3a
Pesukoneet, joiden yläkulma on erittäin ulkoneva.

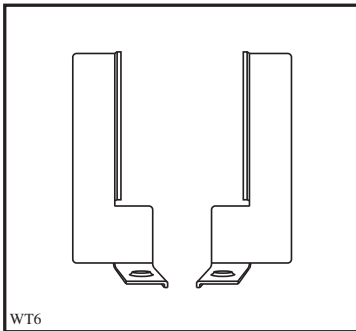

Kuva 2b
Pientä metallikiinnityslevyä käytetään pesukoneissa, joiden yläkulma on hieman ulkoneva.

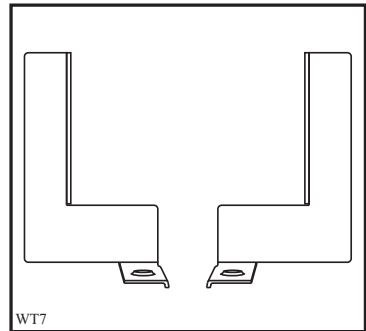

Kuva 3b
Suurta metallikiinnityslevyä käytetään pesukoneissa, joiden yläkulma on erittäin ulkoneva.

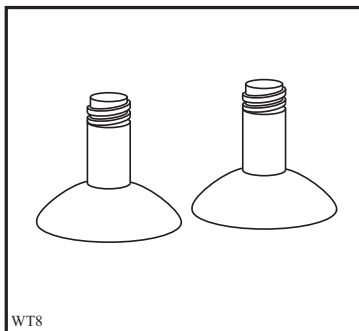

Kuva 4

Pitkiä kumijalkoja (kuva 4) käytetään seuraavissa kuivausrummuissa:

- Mallit ilman sokkelilevyä (kuvat 5 ja 6);
- Mallit, joissa on luukku sokkelilevyssä (kuvat 7 ja 8).

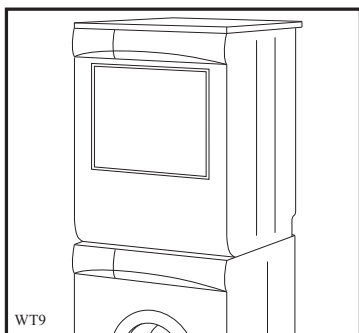

Kuva 5

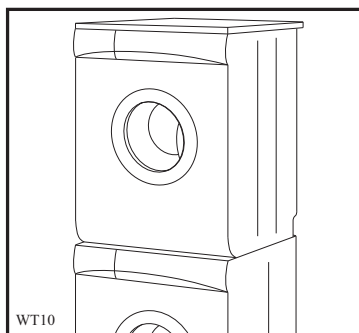

Kuva 6

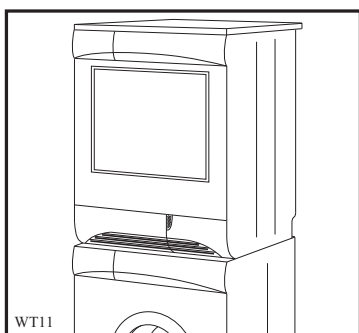

Kuva 7

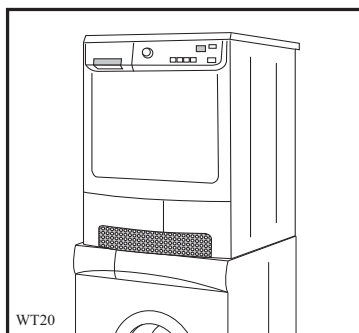

Kuva 8

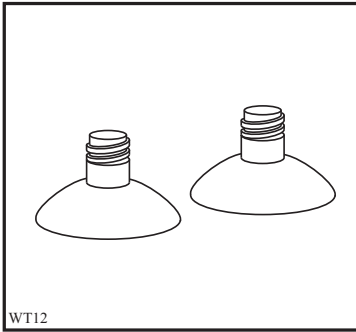

Kuva 9

Lyhyitä kumijalkoja (kuva 9) käytetään seuraavissa kuivausrummuissa:

- Mallit, joissa on sokkelilevy (kuvat 9, 10 ja 11).

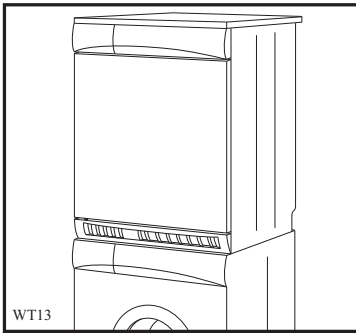

Kuva 10

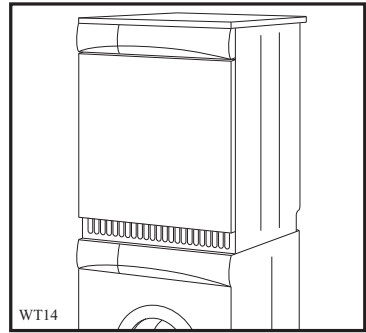

Kuva 11

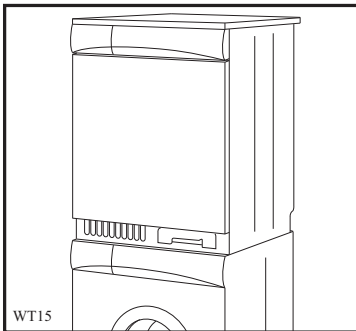

Kuva 12

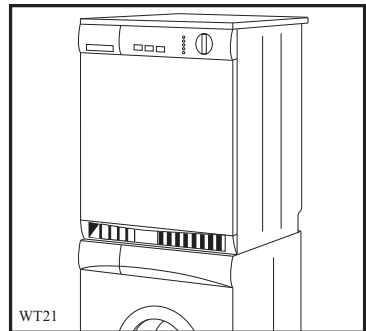

Kuva 13

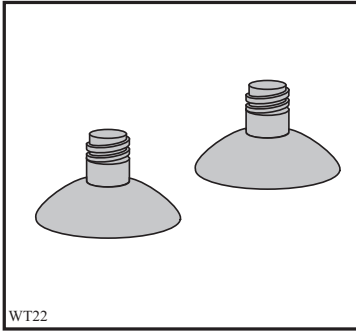

Fig 14

Lyhyitä kumijalkoja harmaita (kuva 14) käytetään seuraavissa kuivausrummuissa:

- Mallit, joissa on luukku sokkelilevyssä (fig 15,16 ja 17).

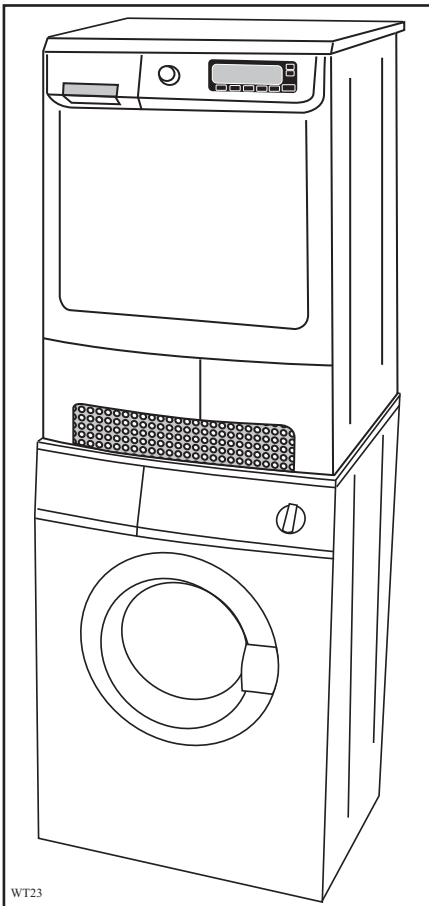

Fig 15

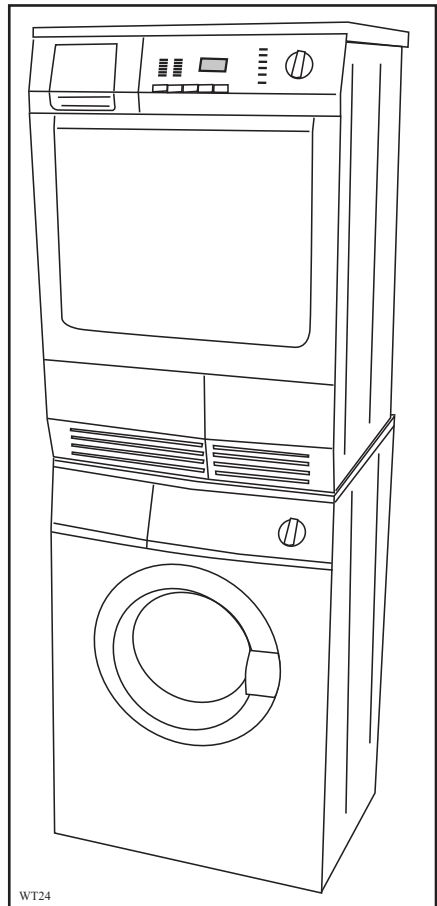

Fig 16

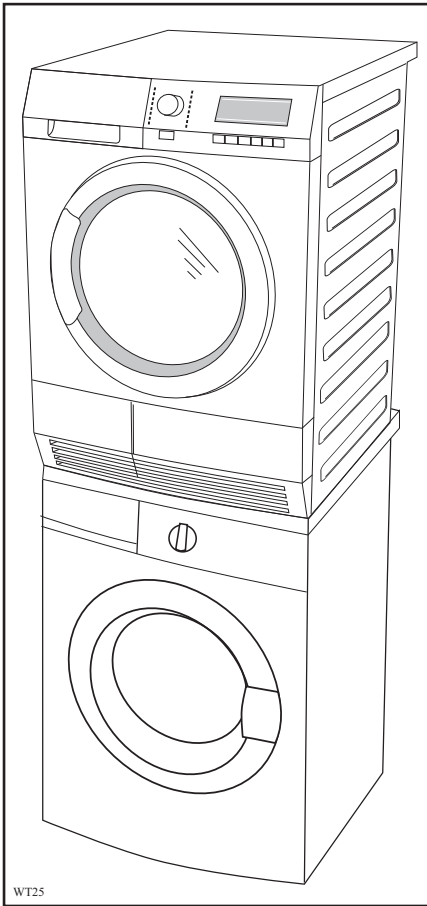

Fig 17

Набор для установки друг на друга стиральных и сушильных машин

Этот набор позволяет экономить занимаемое место и может поставляться для всех стиральных машин с передней загрузкой глубиной 60 см и шириной в пределах 55 - 60 см.

Процедура:

- Положите сушильную машину на правую сторону, обращая внимание на то, чтобы не повредить ее корпус;
- Снимите передние ножки (рис. 1) и замените их на соответствующие резиновые ножки (рис. 1а).



рис. 1



рис. 1а

- Установите сушильную машину над стиральной и отверните 2 винта, расположенных на правой и левой стороне задней панели сушильной машины.
- Приложите соответствующие металлические крепежные пластины (рис. 2b/3b) и прикрепите их входящими в комплект винтами (A+B), как к сушильной машине, так и к верхним кромкам.

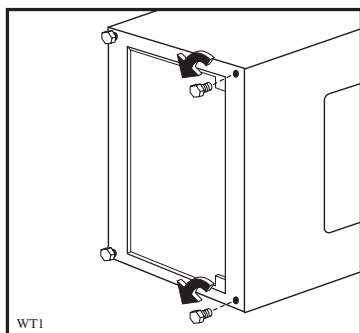

рис. 2 Малая металлическая крепежная пластина

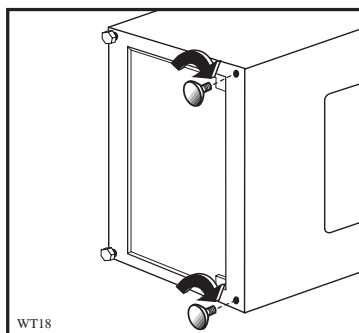

рис. 3 Большая металлическая крепежная пластина

винты А = винты-саморезы 4,2х13
винты В = положение винтов

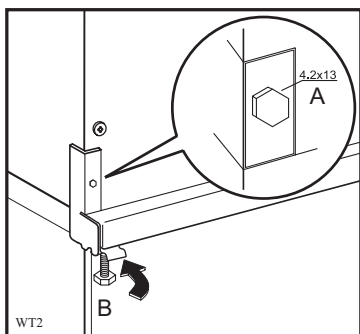
На приведенных ниже рисунках показывается тип металлической пластины, который необходимо использовать в зависимости от ножки на различных моделях стиральной и сушильной машины.

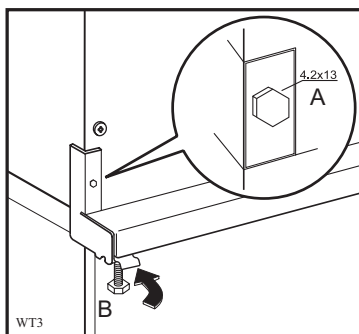

рис. 2а

Стиральные машины с мало выступающей верхней кромкой

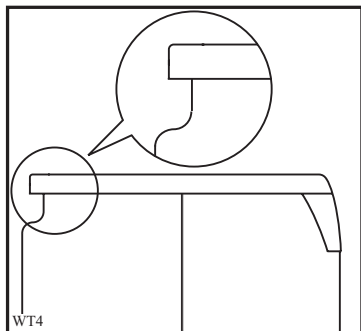

рис. 3а

Стиральные машины с сильно выступающей верхней кромкой

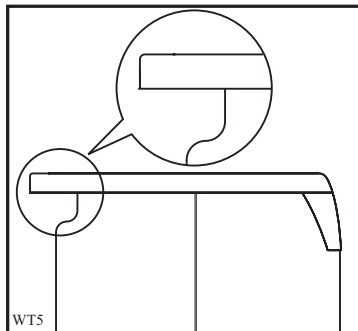

рис. 2b

Малая металлическая крепежная пластина, используемая на стиральных машинах с мало выступающей верхней кромкой

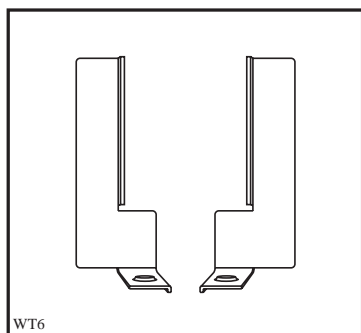

рис. 3b

Большая металлическая крепежная пластина, используемая на стиральных машинах с сильно выступающей верхней кромкой

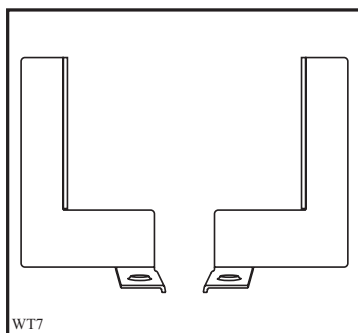

рис. 4

Длинные резиновые ножки (рис. 4), используются на следующих моделях сушильных машин:

- модели без плинтуса (рис. 5 и 6)
- модели с дверцей на плинтусе. (рис. 7 и 8)

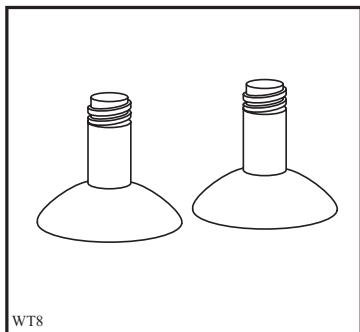

рис. 5



рис. 6

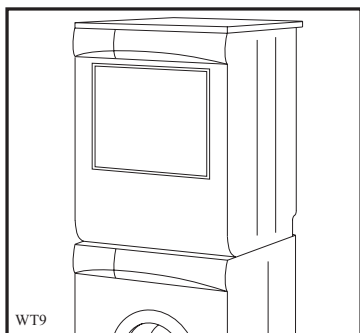

рис. 7

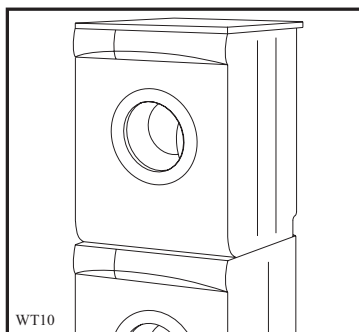

рис. 8

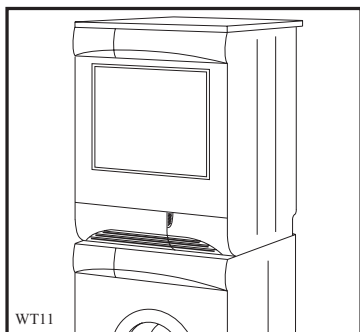

Короткие резиновые ножки (рис. 9),
используются на следующих моделях
сушильных машин:

- модели с плинтусом
(рис. 10, 11, 12 и 13)

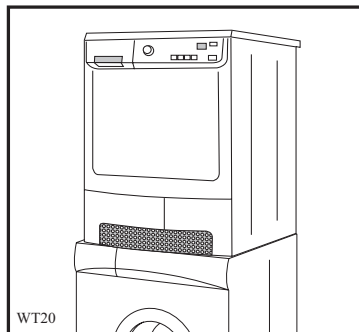
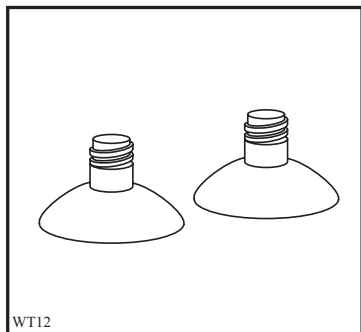

рис. 10



рис. 11

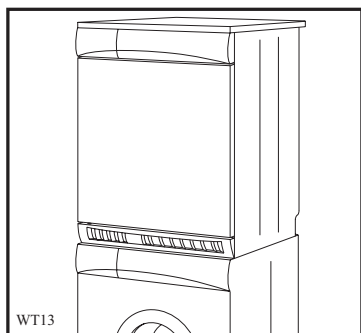

рис. 12

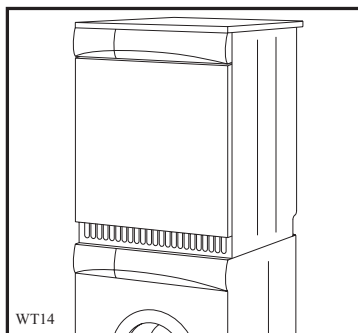

рис. 13

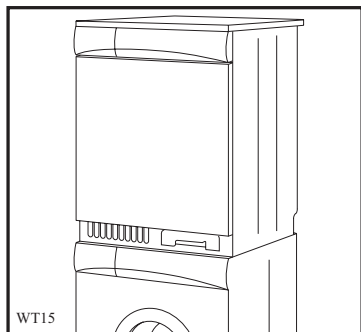

Короткие резиновые ножки (рис. 14), используются на следующих моделях сушильных машин:

- модели с дверцей на плинтусе. (рис. 15, 16 и 17)

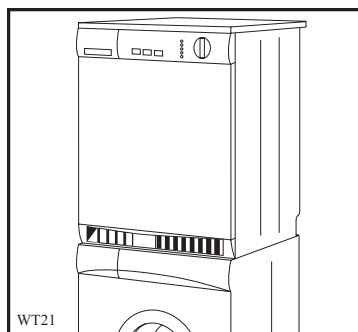
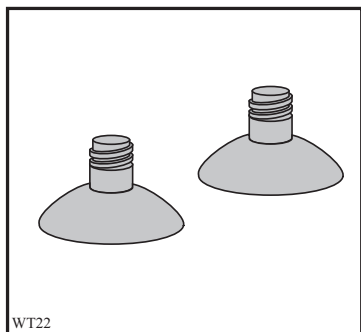
рис. 14



рис. 15



рис. 16

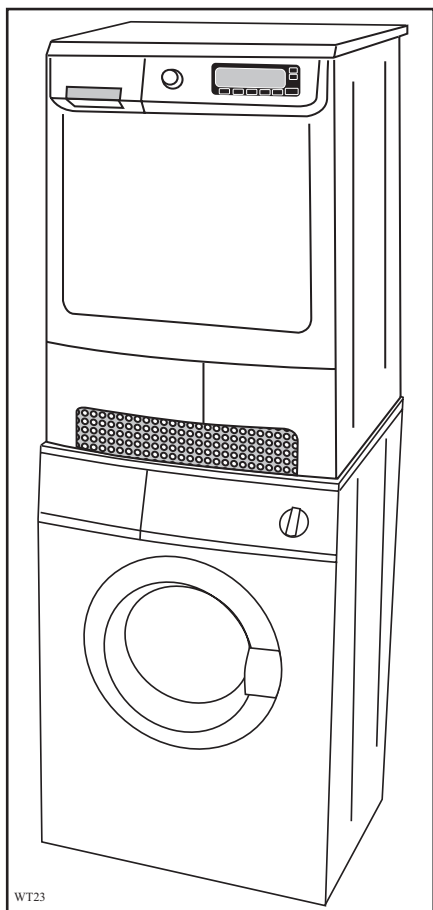

WT25

рис. 17

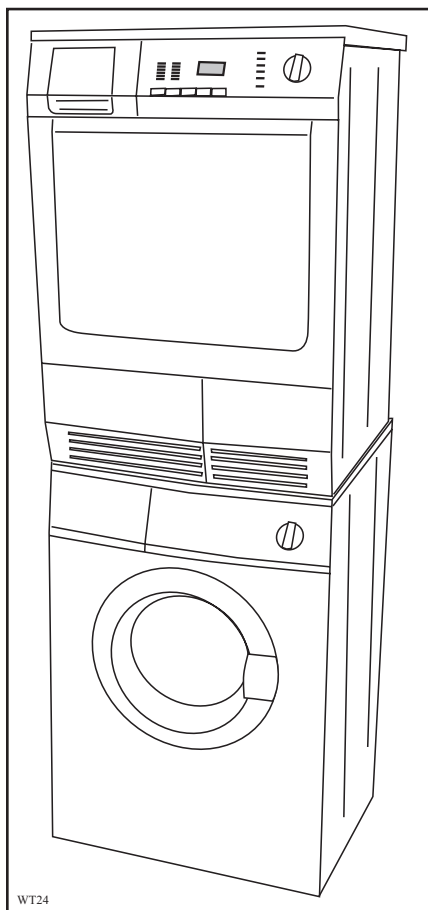
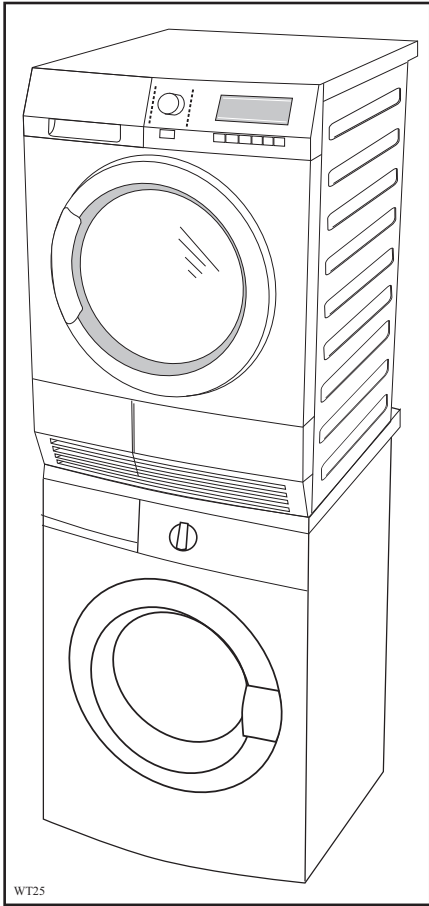
Κιτ για τη συναρμολόγηση σε στήλη πλυντηρίων και στεγνωτηρίων

Το κιτ συναρμολόγηση σε στήλη για να μειωθεί ο χρησιμοποιούμενος χώρος είναι διαθέσιμος για όλα τα πλυντήρια με γέμισμα έμπροσθεν πλάτους 60cm και βάθους μεταξύ 55 και 60cm.

Διαδικασία:

- Αποθέστε το στεγνωτήριο στο δεξί πλευρό προσέχοντας να μην προκληθούν ζημιές στη δομή
- Αφαιρέστε τα πρόσθια ποδαράκια (εικ. 1) και αντικαταστήστε τα με τα αντίστοιχα λαστιχένια ποδαράκια (εικ. 1a).

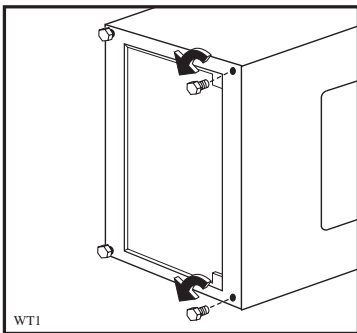

εικ. 1

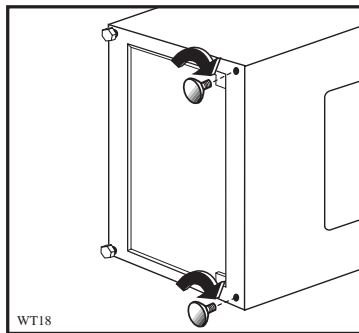

εικ. 1a

- Τοποθετήστε το στεγνωτήριο πάνω από το πλυντήριο και ξεβιδώστε τις 2 βίδες που βρίσκονται στο δεξί και αριστερό πλευρό πίσω από το στεγνωτήριο.
- Μοντάρετε τις αντίστοιχες μεταλλικές πλάκες στερέωσης (εικ. 2b/3b) και στερεώστε τις με τις παρεχόμενες βίδες (A+B) τόσο στο στεγνωτήριο όσο και στις επάνω προεξοχές.

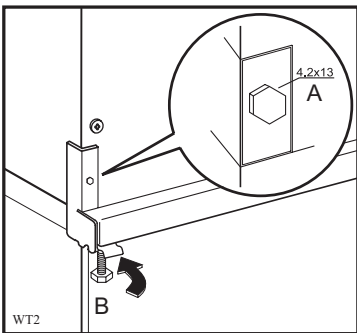

εικ. 2 Μεταλλική πλάκα στερέωσης μικρή

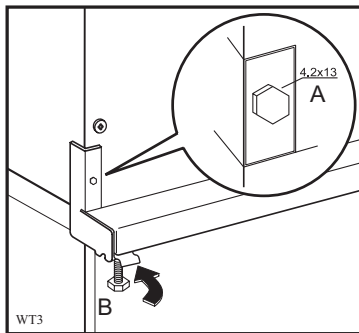

εικ. 3 Μεταλλική πλάκα στερέωσης μεγάλη

βίδες A = βίδες αυτόματης εμπλοκής 4,2x13

βίδες B = τοποθέτηση βιδών

Οι ακόλουθες εικόνες δείχνουν τον τύπο μεταλλικής πλάκας για χρήση ανάλογα με τα ποδαράκια για τα διάφορα μοντέλα πλυντηρίου και στεγνωτηρίου.

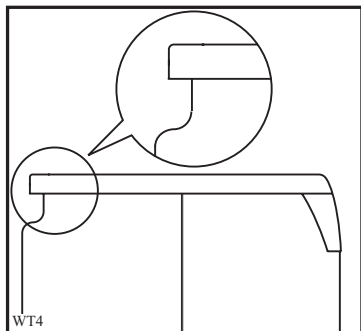

εικ. 2a

Πλυντήρια με προεξοχή επάνω που προεξέχει λίγο

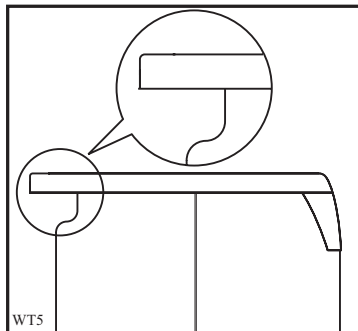

εικ. 3a

Πλυντήρια με προεξοχή επάνω που προεξέχει πολύ

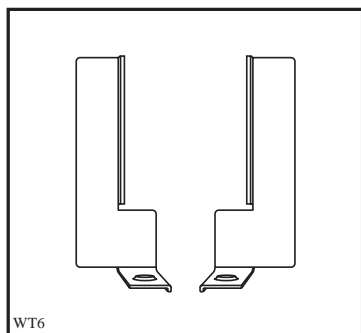

εικ. 2b

Μεταλλική πλάκα στερέωσης μικρή για χρήση για πλυντήρια με επάνω προεξοχή που προεξέχει λίγο

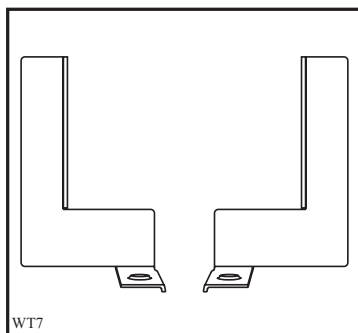

εικ. 3b

Μεταλλική πλάκα στερέωσης μεγάλη για χρήση για πλυντήρια με επάνω προεξοχή που προεξέχει πολύ

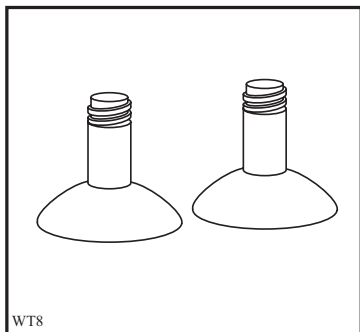

εικ. 4

Λαστιχένια ποδαράκια (εικ. 4) για χρήση στα ακόλουθα μοντέλα στεγνωτηρίων:

- μοντέλα χωρίς βάση (εικ. 5 και 6)
- μοντέλα με πορτάκι στη βάση. (εικ. 7 και 8)

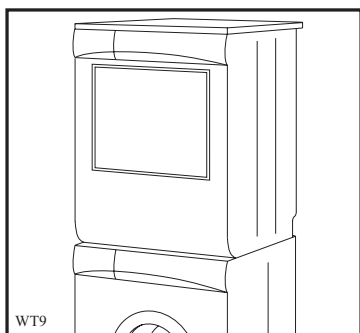

εικ. 5

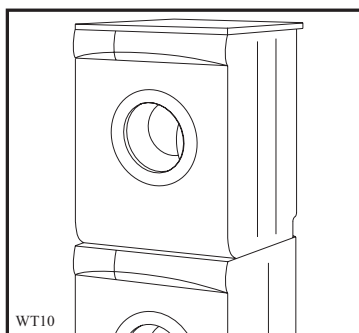

εικ. 6

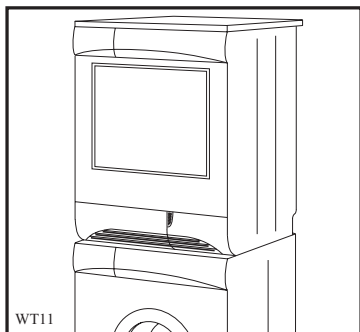

εικ. 7

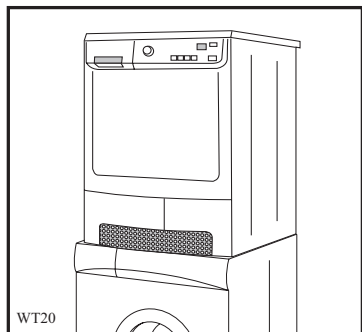

(εικ. 8)

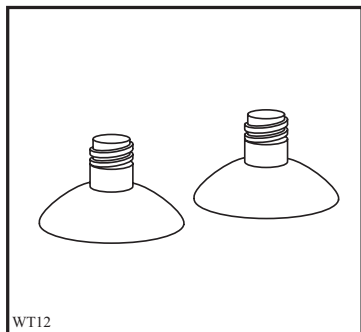

WT12
ΕΙΚ. 9

Λαστιχένια ποδαράκια κοντά (εικ. 9) για χρήση στα ακόλουθα μοντέλα στεγνωτηρίων:

- Μοντέλα με βάση (εικ. 10, 11, 12 και 13)

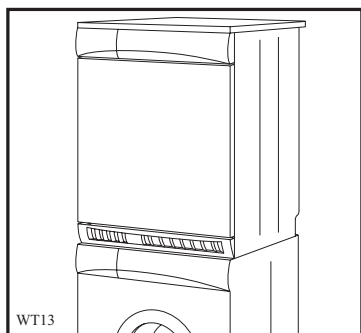

WT13
ΕΙΚ. 10

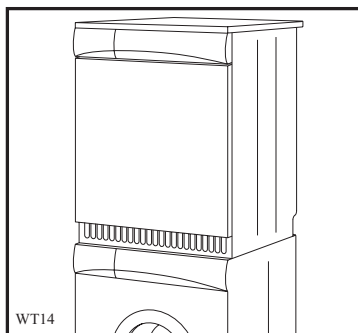

WT14
ΕΙΚ. 11

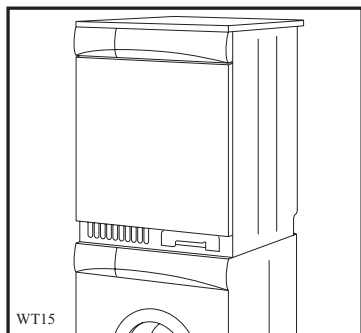

WT15
ΕΙΚ. 12

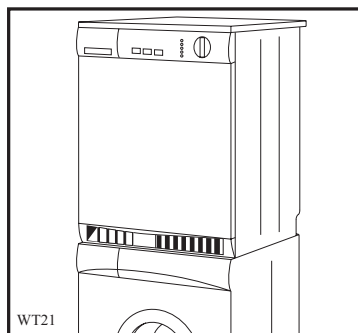

WT21
ΕΙΚ. 13

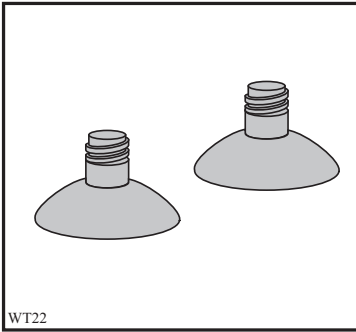

Λαστιχένια ποδαράκια κοντά (εικ. 14),
χρήση στα ακόλουθα μοντέλα
στεγνωτηρίων:

- μοντέλα με πορτάκι στη βάση.
(εικ. 15, 16 και 17)

(εικ. 14)

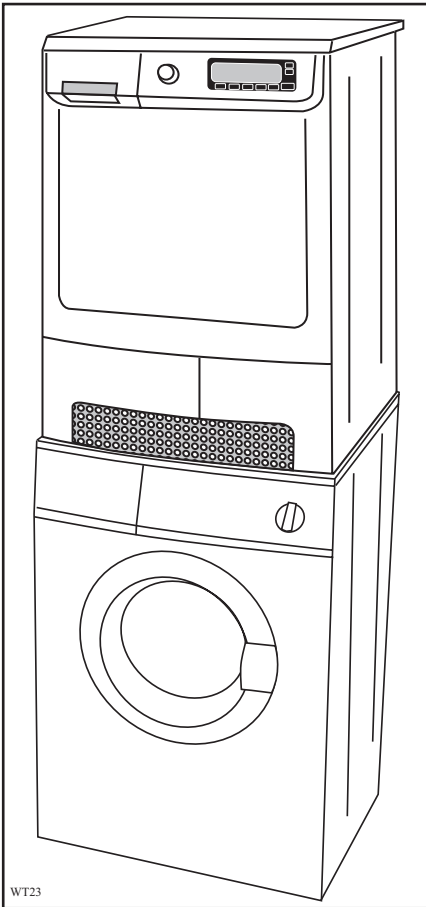

(εικ. 15)

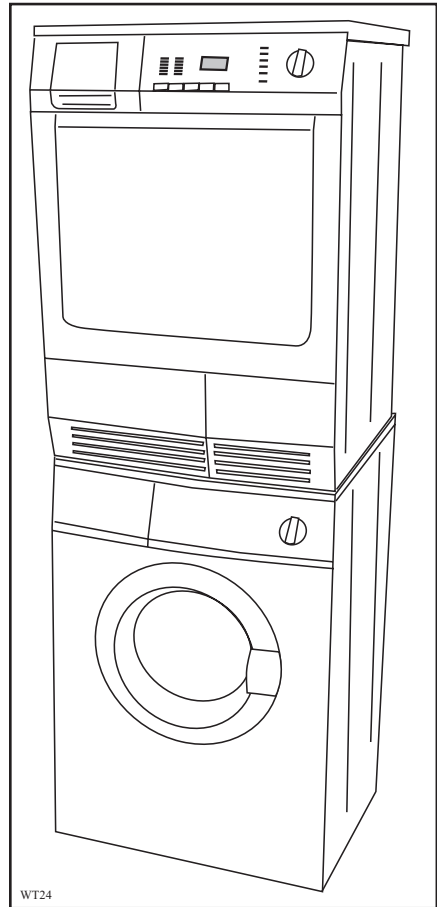

(εικ. 16)

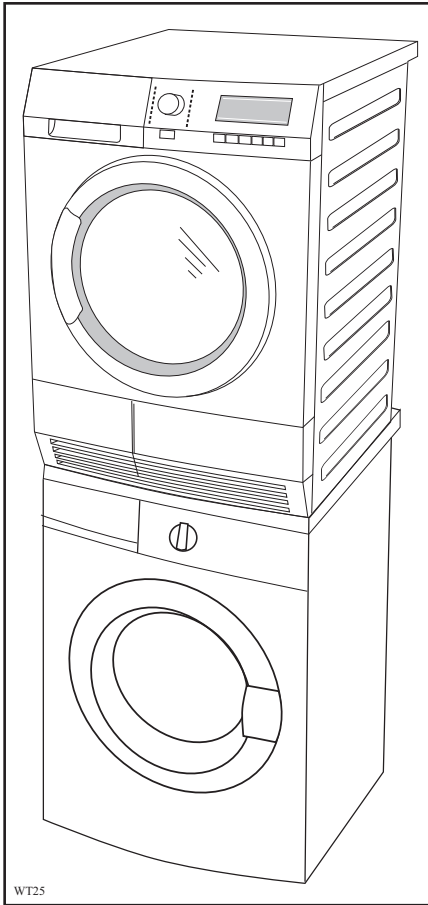

WT25

ΕΚΛ. 17

Çamaşır makineleri ve kurutucuların kolon montajı takımı

Kullanılan alanı ufaltmak için kolon montaj takımı, genişliği 60 cm ve derinliği 55 ve 60 cm arasında kapsanan önden yüklemeli tüm çamaşır makineleri için mevcuttur.

Yöntem:

- Gövdesine zarar vermemeye dikkat ederek kurutucuyu sağ yan üzerine yaslayınız.
- Ön ayakları çıkarınız (res. 1) ve bunlara ilişkin lastik ayaklar ile değiştiriniz (res. 1a).

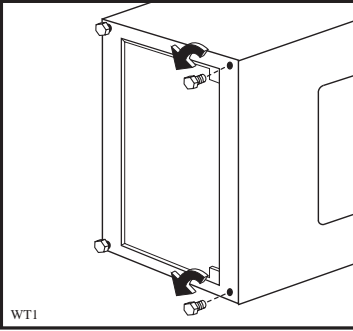

res. 1

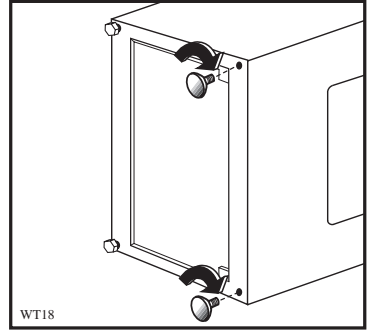

res. 1a

- Kurutucuyu çamaşır makinesi üzerine yerleştiriniz ve kurutucunun arkasındaki sağ ve sol yanlarında bulunan 2 vidayı çözünüz.
- İlişkin metal sabitleme plakalarını takınız (res. 2b/3b) ve gerek kurutucu gerekse üst köşeler üzerinde ikmal edilmiş vidalar ile (A+B) sabitleyiniz.

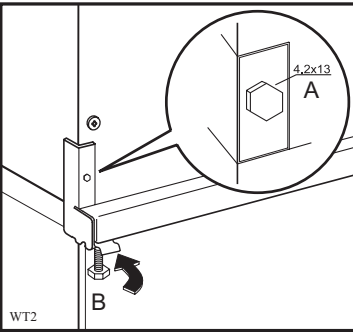

res. 2 Küçük metal sabitleme plakası

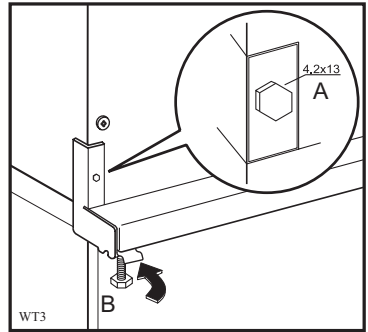

res. 3 Büyük metal sabitleme plakası

A vidaları = kendinden dişli vidalar 4,2x13

B vidaları = vidaların yerleştirilmesi

Aşağıdaki resimler, farklı çamaşır makineleri ve kurutucu modelleri için ayaklara göre kullanılacak metal plaka tipini göstermektedirler.

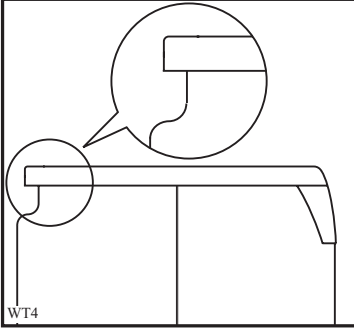

res. 2a

Az d̄şar sarkan üst köşeli
çamaşır makineleri

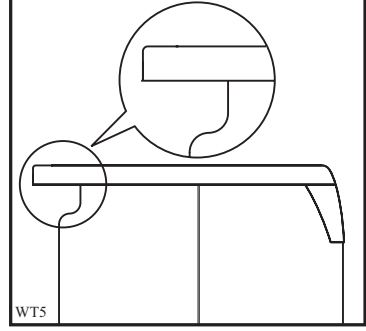

res. 3a

Çok d̄şar sarkan üst köşeli
çamaşır makineleri

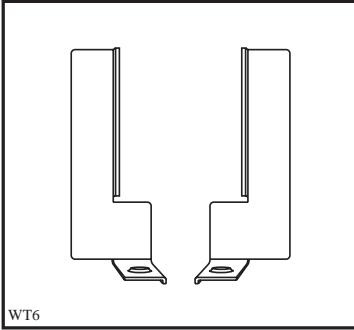

res. 2b

Az d̄şar sarkan üst köşeli
çamaşır makineleri için
kullanılacak küçük metal
sabitlenme plakası

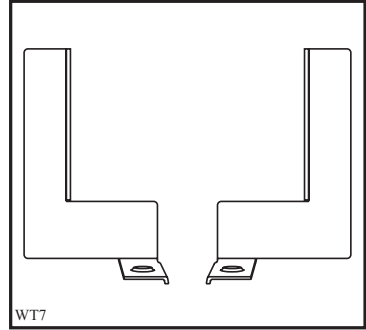

res. 3b

Çok d̄şar sarkan üst köşeli
çamaşır makineleri için
kullanılacak büyük metal
sabitlenme plakası

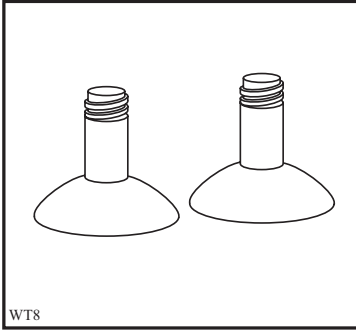

res. 4

Aşağıdaki kurutucu modelleri için kullanılabilecek uzun lastik ayaklar (res. 4):

- tabansız modeller (res. 5 ve 6)
- taban üzerinde ufak kapaklı modeller (res. 7 ve 8)

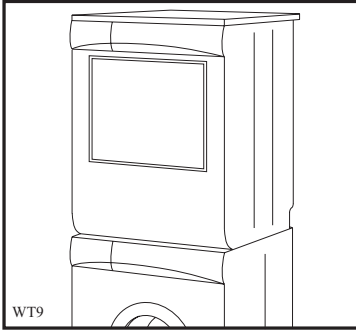

res. 5

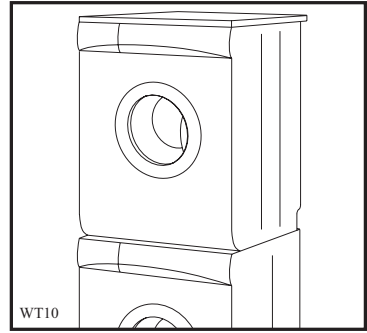

res. 6

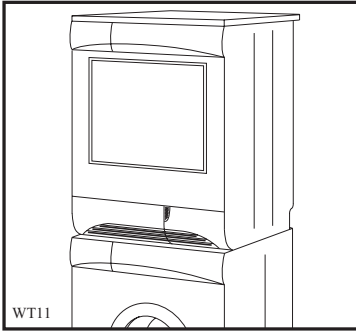

res. 7

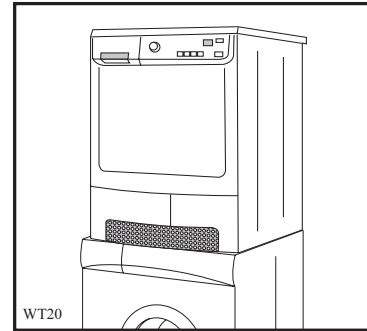

res. 8

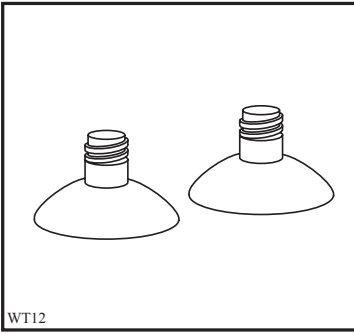

res. 9

Aşağıdaki kurutucu modelleri için kullanılabilecek kasa (res. 9) lastik ayaklar:

- Tabanlı modeller (res. 10, 11, 12 ve 13).

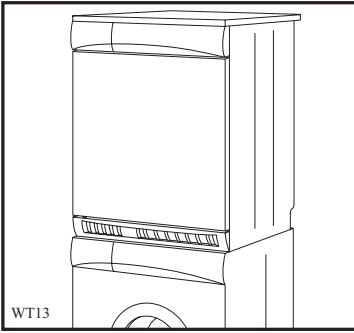

res. 10

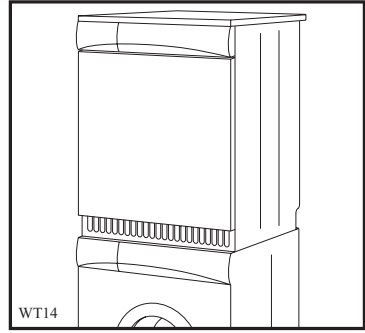

res. 11

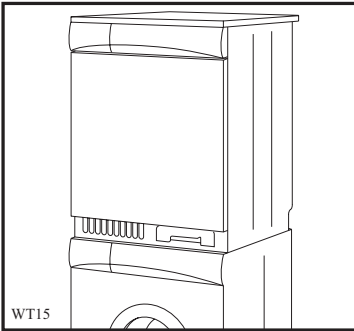

res. 12

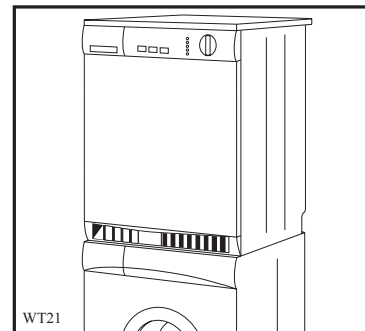

res. 13

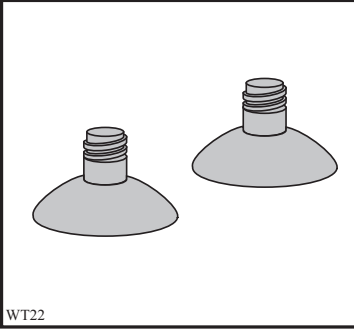

(res. 14)

Aşağıdaki kurutucu modelleri için kullanılacak kısa (res. 14)lastik ayaklar:

- taban üzerinde ufak kapaklı modeller. (res. 15, 16 ve 17)

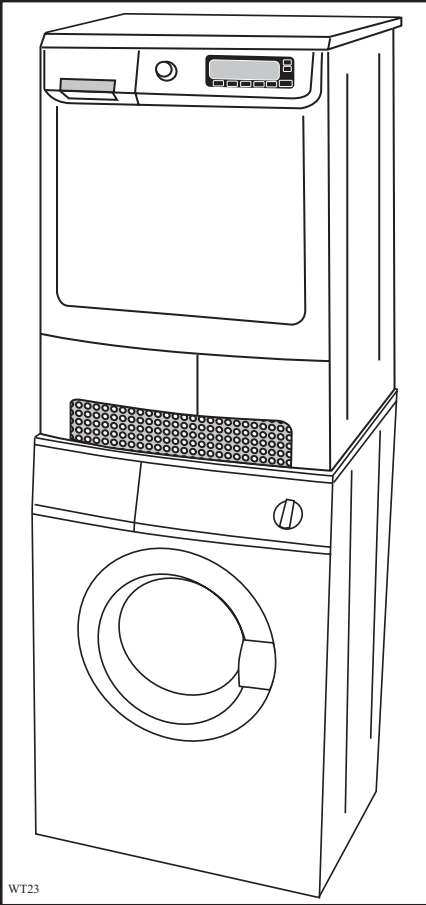

(res. 15)

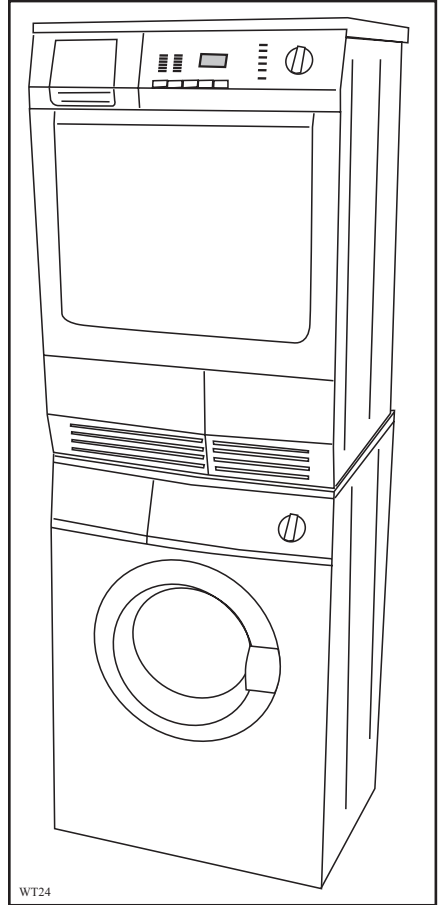

(res. 16)

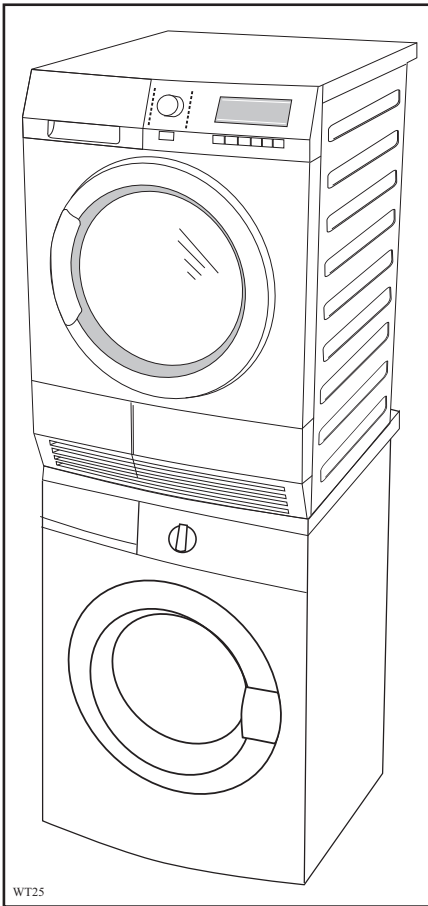

WT25

(res.17)

